

**WALWORTH**®  
*Since 1842*

FLOATING BALL VALVE  
**CATALOG**





# INDEX

## INTRODUCTION

|                                    |   |
|------------------------------------|---|
| WALWORTH ENGINEERING CONTROL ..... | 5 |
| WALWORTH QUALITY SYSTEM.....       | 5 |
| QUALITY CONTROL EQUIPMENT.....     | 9 |

## FLOATING BALL VALVES

|   |    |
|---|----|
| INTRODUCTION OF FLOATING BALL VALVES .....                            | 11 |
| STRUCTURAL FEATURES.....  | 12 |
| FLOATING BALL CLASS 600 WOG.....                                      | 14 |
| FLOATING BALL CLASS 1000 WOG & 2000 WOG .....                         | 17 |
| STANDARD FLOATING BALL CLASS 150, 300 & 600 .....                     | 21 |
| FIRE SAFE FLOATING BALL VALVES 150, 300 & 600.....                    | 26 |
| FIRE SAFE FLOATING BALL VALVES 1500 .....                             | 34 |
| FIRE SAFE FLOATING BALL VALVES 800, 1500 & 2500 (THD OR SW ENDS)..... | 37 |
| ACCESSORIES FOR OPERATION.....  | 42 |
| PRESSURE-TEMPERATURE RATINGS .....                                    | 42 |
| TORQUES AND CV FLOW RATES.....  | 45 |
| BODY AND TRIM MATERIALS .....   | 45 |
| FLOATING BALL VALVE FIGURES .....                                     | 46 |
| HOW TO ORDER.....   | 47 |
| DESIGN BASIS.....   | 48 |
| TERMS AND CONDITIONS.....   | 50 |



YARMOUTH RESEARCH AND TECHNOLOGY



# WALWORTH

WALWORTH is one of the world's most comprehensive industrial valve manufacturers. Founded in 19th century by James Walworth, the Company has consistently dedicated itself to improvements in design and manufacturing of an array of valves exceptionally suited for the world's fluid control sector. We satisfy all end use industries and comprehensive customer requirements by adhering to the most demanding quality standards.

WALWORTH relies on its broad experience in supplying valves to the petrochemical, oil & gas, petroleum, power generation, pulp and paper, cryogenic and geothermal industries, among others.

Over the years, Walworth has produced over 40,000 different types of products and serves as a global supplier to various markets utilizing the expertise of over 500 trained employees.

Our manufacturing system includes: utilization of Company directed raw material warehouses; modern and newly acquired specialized machinery; welding processes such as SMAW, GMAW, SAW, PAW; assembly testing for all low pressure, high pressure, and at low or high temperatures; painting and coating processes; export crating and shipment.

WALWORTH is capable of providing the world's most comprehensive industrial valve line to the North American, Central American, South American, European and African markets. WALWORTH is proud to meet and satisfy the precise demands of our customers throughout the world by providing a quality product, competitive cost, and excellent service.



## WALWORTH VALUES

### MISSION

WALWORTH manufactures and supplies world-class valves and components for the flow control industry through exceptional service, competitive pricing, and consistently, on-time deliveries.

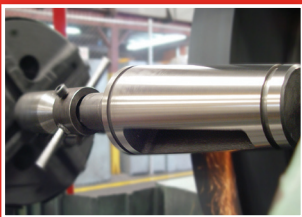

### VISION

To be the world leader of unparalleled valve manufacturing and supply, WALWORTH:

- Set the standard for product quality in the flow control industry.
- Exceed the service expectations of our customers.
- Forge enduring relationships with customers, team members, and community.
- Hire, develop, and retain experienced and dedicated team members.



# WALWORTH ENGINEERING CONTROL

WALWORTH products are manufactured following strictly the most recognized international standards all over the world, such as API, ANSI, ASME, ASTM, MSS, NACE, AWWA, BSI, CSA, among others. Our Engineering team is always studying the new updates of these standards to incorporate any changes that may affect the design, regulations or performance of our products, being leaders in the new developments achieved.

Design is made using the most advanced technology and equipment, using finite elements and CAD system programs to ensure the proper assembly and performance of products since the concept, calculation and detailed drawings for manufacturing. WALWORTH is a leader in the development of new products according to valve market current needs.

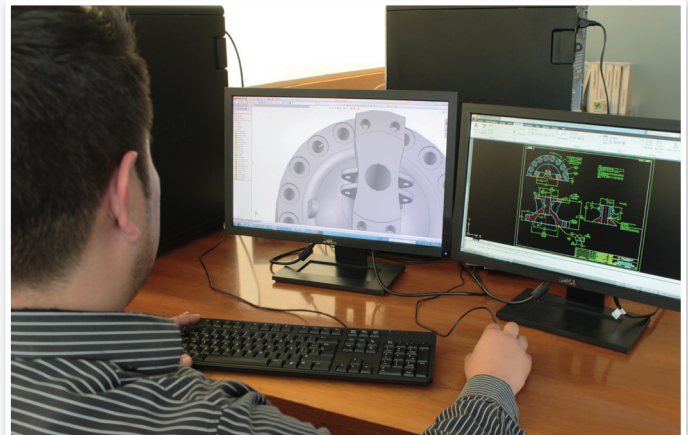

# WALWORTH QUALITY SYSTEM

Throughout the years, WALWORTH has developed its Quality System which is an integral part of our manufacturing policy. Our primary goal is to provide products that meet and exceed market standards. In this sense, WALWORTH is an ISO-9001 Audited and Certified Company that has achieved major certifications worldwide. Our system includes the selection of raw materials from approved vendors, and rigorous oversight of our manufacturing process that is vital to quality control. The use of serial numbers allows WALWORTH the ability to not only ensure the quality of components used but to monitor and trace the fabrication process as well.

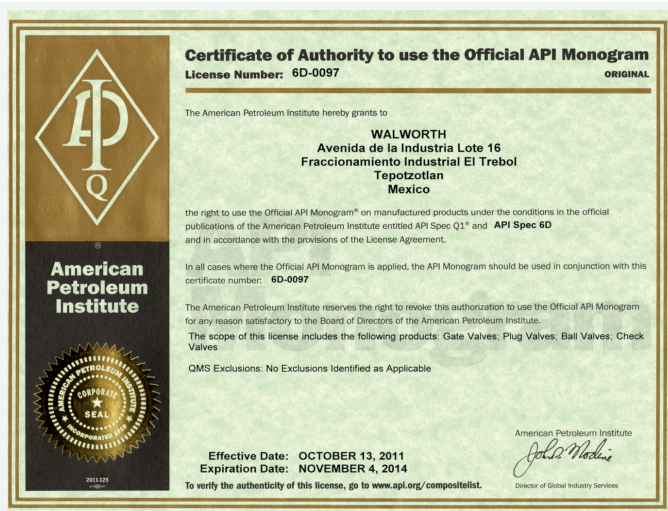

### Certificate API-6D No. 6D-0097

Issued by American Petroleum Institute to apply on Gate valves, Plug valves, Ball valves and Check valves manufactured in accordance with API-6D specification.

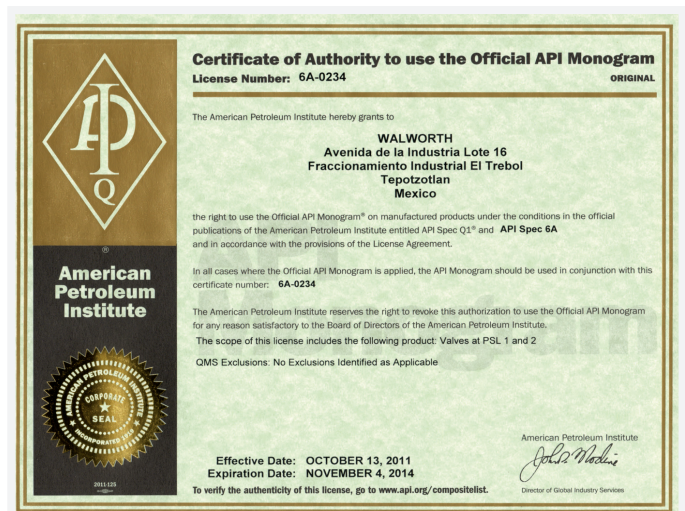

### Certificate API-6A No. 6A-0234

From American Petroleum Institute to apply on valves at PSI, 1 through 4.

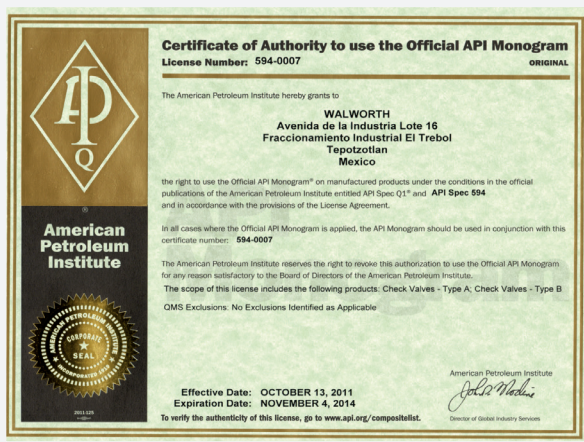

**Certificate API-594 No. 594-0007**

Issued by American Petroleum Institute to apply on Check Valves-Type A; Check Valves Type B manufactured in accordance with API-594 specification.



**API-600 Certificate No. 600-0109**

Issued by American Petroleum Institute to apply on Bolted Bonnet Steel Gate Valves manufactured in accordance with API-600 specification.



**API-602 Certificate No. 602-0024**

Issued by American Petroleum Institute to apply on Compact Steel Gate Valves, Compact Steel Globe Valves, and Compact Steel Check Valves manufactured in accordance with API-602 specification.



**Certificate ISO-9001 No. 0038**

Issued by American Petroleum Institute since April 1999.



**Certificate as per PED 97/23/EC Module H**

To stamp CE products.



**Supplier Qualification Certificate NO. 279/13**  
 Issued by the Equipment and Materials Testing Laboratory, CFE (LAPEM in Spanish)



**Certificate NMX-CC-9001 (Mexican Standards ISO-9001) No. 0552/2007**  
 Issued by PEMEX in accordance with ISO-9001 Quality Assurance System.

## PRODUCT CERTIFICATIONS



**Emissions after 500 cycles at ambient and 350 °F**  
 Issued by Yarmouth Research and Technology Lab for 3 inch Class 300 Gate Valve After 500 cycles the measurement result was less than 50 ppm.



**Emissions after 500 cycles at ambient and 350 °F**  
 Issued by Yarmouth Research and Technology Lab for 8 inch Class 300 Gate Valve After 500 cycles the measurement result was less than 50 ppm.



**Emissions after 500 cycles at ambient and 350 °F**  
 Issued by Yarmouth Research and Technology Lab for 16 inch Class 150 Gate Valve After 500 cycles the measurement result was less than 50 ppm.





**YARMOUTH RESEARCH AND TECHNOLOGY**

---

**PROJECT SUMMARY**

**Project Number:** 99069  
**Customer:** The Walworth Company  
**Contact:** David Cornelsen  
**Date(s) of Test:** 12/8/99 – 12/20/99  
**Product(s) Tested:** One 6" Class 300 Gate Valve with Empak-Mex EAF-100-001 packing.  
**Purpose of Test:** The test was conducted to evaluate the valve's stem sealing performance at ambient and at 350° F as related to the 1990 Amendments to the Clean Air Act requirements. Leakage measurements were conducted in accordance with 40 CFR Part 60, Appendix A, Method 21.  
**Conclusion:** Three thermal cycles from ambient to 350 deg. F were conducted throughout 3500 open/close cycles with the valve pressurized to 645 psig. The valve was cycled with a 43 RPM gear motor coupled to the handwheel. One packing nut adjustment was required at cycle number 300 to maintain leakage levels below 100 PPMv.  
 At cycle number 3500, the packing leakage was 25-29 PPMv with the stem static. The packing nuts were tightened from 12/14 ft-lb back to 28 ft-lb and leakage decreased to about 1 PPMv.  
 See the attached data sheets for more information.

**Test Witness:**   
 Matthew J. Wasielewski, P.E., President  
 YARMOUTH RESEARCH AND TECHNOLOGY



Phone or Fax (207) 846-1686  
 92 East Elm Street P.O. Box 539 Yarmouth, Maine 04996-0539

**TÜV Rheinland®**

**Certificate**

**Certificate No.** TRASA 700-13-0019

**Customer** WALWORTH MEXICO – Industrial de Válvulas S.A. de C.V.  
 Av. de la Industria Lote 16  
 Fracc. Industrial El Trebol, C.P. 54600  
 Tepotzotlán, Estado de México

**Product Tested** API 6D Trunnion mounted bolted body ball valves, carbon steel (A105-WCB) construction, double block and bleed service, primarily used but not limited to the oil and gas standard and severe applications.

**Trademark** "WALWORTH"

**Model / Type** Model 800X with metal to metal seat or soft seat

| GROUP   | DESCRIPTION  |
|---------|--|
| GROUP A | Two way Trunnion type, Inseparable Ball Valves, Diameters 2 to 4 in. Process connection ASME/ANSI B16.34 Class 150 / Class 300. Metal to Metal or Soft seat                |
| GROUP B | Two way Trunnion type, Inseparable Ball Valves, Diameters 6 to 12 in. Process connection ASME/ANSI B16.34 Class 150 / Class 300. Metal to Metal or Soft seat               |
| GROUP C | Two way Trunnion type, Inseparable Ball Valves, Diameters 14 to 24 in. Process connection ASME/ANSI B16.34 Class 150 / Class 300. Metal to Metal or Soft seat              |
| GROUP D | Two way Trunnion type, Inseparable Ball Valves, Diameters 30 to 48 in. Process connection ASME/ANSI B16.34 Class 150 / Class 300. Metal to Metal or Soft seat              |
| GROUP E | Two way Trunnion type, Inseparable Ball Valves, Diameters 2 to 4 in. Process connection ASME/ANSI B16.34 Class 600 / Class 900 / Class 1500. Metal to Metal or Soft seat   |
| GROUP F | Two way Trunnion type, Inseparable Ball Valves, Diameters 6 to 12 in. Process connection ASME/ANSI B16.34 Class 600 / Class 900 / Class 1500. Metal to Metal or Soft seat  |
| GROUP G | Two way Trunnion type, Inseparable Ball Valves, Diameters 14 to 24 in. Process connection ASME/ANSI B16.34 Class 600 / Class 900 / Class 1500. Metal to Metal or Soft seat |
| GROUP H | Two way Trunnion type, Inseparable Ball Valves, Diameters 30 to 48 in. Process connection ASME/ANSI B16.34 Class 600 / Class 900 / Class 1500. Metal to Metal or Soft seat |

**Applicable Standard** IEC 61508:2010 Part 2 and IEC 61511:2003 Part 1

**TUV Report No.** 700-13-0019

**Results** Systematic Integrity: SIL 3 Capable  
 Random Integrity: Type A  
 PFDexp and architecture constraints must be verified for each application

**Safety Function** This Trunnion Ball Valves will move to the designed safe position per the actuator design. The safe position are Full Open / Full Stroke – FO / Full Closed / Tight Shut-Off – TSO.

**Specific Requirements** The Safety Manual and the User's manual for installation, maintenance and operating the ball valves must be considered.  
 The prerequisites for Functional Safety intended used in report TUV 700-13-0019 must be considered.

Buenos Aires, January 23th, 2014

  
 Eng. Mauricio Schamber

Note: The TÜV Report No. 700-13-0019 is an integral part of this certificate.  
 This certificate is valid only for products which are identical with the product tested. It becomes invalid at any change of the codes and standards forming the basis of testing for the intended application.

Page 1 of 3

**Certificates of Ultra Low Fugitive Emissions No. 20985-3, 8 & 16 in accordance with ISO-15848-1 "Industrial Valves" Measurement, Test and Qualification Procedures for Fugitive Emissions "Part 1: Classification System and Qualification Procedures for Type Testing of Valves".**

**TÜV Rheinland Certificate No. TRASA 700-13-0019**  
 API-6D Trunnion mounted bolted body ball valves, carbon steel (A105-WCB) construction, double block and bleed service, primarily used but not limited to the oil and gas standard and severe applications.

**DACOR SERVICES**  
 CONSULTANTS  
 ENGINEERING • QUALITY ASSURANCE • MANUFACTURING  
 DAVID J. CORNELSEN, P.E., PRESIDENT

January 22, 2005

Ruben Paredes  
 Walworth – Inval Facility  
 Av. De la Industria Lote 16 Fracc. Industrial el Trebol  
 Tepotzotlan, Edo. De Mexico  
 CP 54600, Mexico

**Reference:** Witness Report – API Spec 6FA Fire Test Number 01-1/05

This will certify that the following listed valve successfully passed all requirements of API Specification 6FA Fire Test for Valves, Third Edition dated April 1999 and API Standard 607 Fire Test for Soft-Seated Quarter-Turn Valves, Fourth Edition dated May 1993. The tests were made and verified on January 21, 2005.

API 6D Trunnion Mounted Ball Valve, 12-inch Class 150 Figure 8122, Serial Number V05B01.

The successful test of the 12-inch Class 150 API 6D Ball Valve qualifies this design/type of valve as meeting the requirements of API Spec 6FA / API Std 607 for sizes 12-inch through 24-inch in pressure classes 150 and 300.

Sincerely,  
  
 David J. Cornelsen P.E.  
 President



24802 MATHER DRIVE • KATY, TEXAS 77494  
 TELEPHONE (281) 395-5071 • TELEFAX (281) 395-5013

**CERTIFICATE**  
 Certificate No.: 01 202 USA-TA-09-79768

Concerning the Agreement with the Technical Requirements in:  
**TA-Luft 2002, VDI 2440 Nov. 2000, Sec. 3.3.1.3**

**Test report:** 209140      **Datum:** 03 December, 2009

**Client:** Industrial de Válvulas, S.A. de C.V.

**Manufacturer's Address:** Av. De la Industria Lote 16  
 Fracc. Industrial El Trebol,  
 Tepotzotlan, Edo. De Mexico, CP 54600

The stem sealing system and internal flange connection have been successfully tested to meet the tightness criteria of  $\leq 10^{-4}$  mbar x l/(s x m) with a helium mass spectrometer under the following conditions. The BVV Valve with the examined mechanical shaft seals fulfills the requirements of Section 5.2.6.4 of The German Clean Air Act (TA-Luft). (Leakage Verification) in accordance with Section 3.3.1.3 of VDI 2440 (Rev. 2000).

|  |   |                       |
|--|---|-----------------------|
| <b>Kind of Valve:</b>                  | Walworth API 600 Gate Valve             |                       |
| <b>Valve Type:</b>                     | 4 inch, Class 300, Figure 5206F         |                       |
| <b>Sealing System:</b>                 | WCB Body / CR 13 Stem & Disc / HF Seat  |                       |
| <b>Nominal Size, Nominal Pressure:</b> | 4 inch, ANSI 300                        |                       |
| <b>Inspection Media/Pressure:</b>      | Helium / 51 Bars                        | Temperature = Ambient |
| <b>Switching Cycles: (2/min):</b>      | 0 Cycles                                | Total Cycles 500      |
| <b>Leakage Rate [mbar - l / sec]</b>   | 5.2e-7 (mbar - lsec)                    | 3.7e-6 (mbar - lsec)  |
| <b>Testing Method:</b>                 | Helium Leak Test – VDI 2440, Appendix A |                       |

**Testing Laboratory:** TÜV Rheinland North America, Inc.  
 Industrial Services Division, Newtown, CT, USA  
 YARMOUTH RESEARCH AND TECHNOLOGY  
 Matthew J. Wasielewski, PE  
 434 Walnut Hill Road, N. Yarmouth, ME USA  
 www.yarmouthresearch.com

  
 Kasuma J. Santos, Jr. – Examiner



**Fire Test Certificate No. 01-1/05**  
 In accordance with API-6FA and API Standard API-607 for Trunnion Ball Valves in accordance with API-6D.

**TA Luft Certificate (Fugitive Emission) Approval**  
 ISO-5211 Top Flange, Anti-Static Device.

## QUALITY CONTROL EQUIPMENT

In order to assure that WALWORTH products comply with quality international standards, in-house equipments are kept for monitoring control, some of this equipment includes:

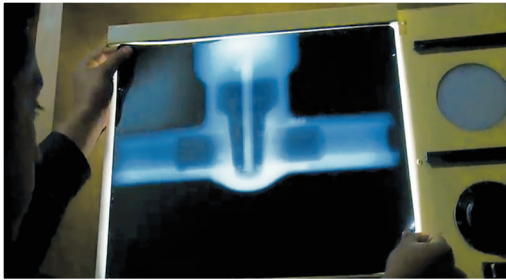

**X-Ray Examination Equipment.**- WALWORTH has its own Ir-92 source in-house for the radiographic examination (RT) of castings from 0.100" up to 2 1/2" wall thickness to verify the soundness of the casting raw material.

**PMI Equipment.**- New generation of Positive Material Identification Equipment gives WALWORTH the capability to perform quick chemical analysis on incoming raw materials and on pieces after assembly to certify that materials used were produced and assembled in accordance with WALWORTH and the Customer's specifications.



**Magnetic Particle Test.**- In a random basis for standard products or when a Customer request MT Certification, WALWORTH has Magnetic Particle Test Equipment to perform on ferromagnetic materials.

**Penetrant Test Examination.**- WALWORTH has the personnel and materials to perform PT examination by solvent removable or water washable techniques. The NDT personnel are ASNT Certified.



**Test Loop.** A complete Laboratory Test loop exists for design validation of WALWORTH products performing the test at maximum design pressure and cycling the valves from 3000 to 5000 cycles. The test expends more than 4 months to be finished.

**Pressure Gradient Test Loop.**- This test exposes Plug valves to the extremes of both positive and negative pressure gradients to verify that the plug in a balanced plug design will prevent lock-up into the body.

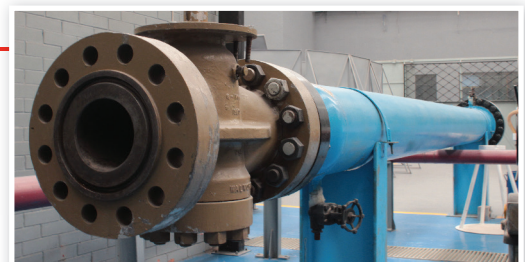



**Metrology Laboratory.**- WALWORTH developed a calibration and/or verification system in all the equipment used in its facilities to ensure the traceability of measurements to international standards. In this way, WALWORTH gets measurement control of its products to comply with international standards.

**Fire Test Facilities.**- Facilities to perform fire test in accordance to API requirements. The test exposes the valve to a fire flame at 1400 to 1800 °F (761 to 980 °C) to verify proper seal of the valve.



**Low Fugitive Emissions Test.**- When a Customer requires low fugitive emissions certification. The Lab has its own LFE Test Equipment capable to measure less than 20 ppm either in both static or Mechanical conditions at ambient temperature or thermal cycle operations.

**Ultrasonic Testing Equipment.**- Using ultrasonic techniques, we can detect sub surface flaws in materials and evaluate castings and forgings that cannot be radiographed. In addition we utilize these techniques to measure the wall thickness of castings and forgings.

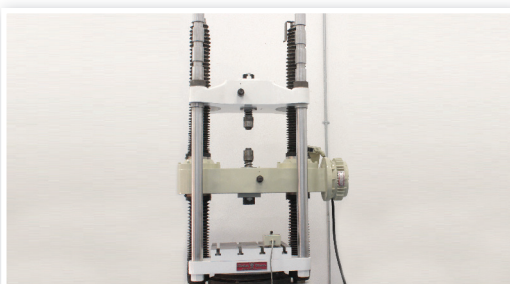

**Tensile Test Equipment.**- To verify the mechanical properties of materials used for manufacturing, WALWORTH tests samples on a random basis even though we receive MTR's from our suppliers and foundries.

**Hardness Test Equipments.**- Either lab or shop test, WALWORTH use hardness tester equipments as Rockwell B, C Brinell or Vickers to check compliance against specifications.



# FLOATING BALL VALVES

This product line is used primarily in the Oil & Gas, Building and construction Industries, Chemical and Petrochemical services, among others. WALWORTH offers Floating Ball valves to provide positive shut-off while minimizing pressure drop.

WALWORTH offers an array of materials used for this product line, including but not limited to:

- a) Carbon Steel such as A-105 or WCB, etc.
- b) Stainless Steel such as CF8, CF8M or F316, etc.
- c) Low Carbon Stainless Steel such as CF3, CF3M, CG3M, etc.
- d) Super Stainless Steel such as CN7M (Alloy 20), CN3M (Alloy 20 modified), CT15C, etc.
- e) Brass like B283 grade C37700, Low Temperature Carbon Steel such as LCB, LCC or LF2, etc.



WALWORTH offers a variety of trim materials including but not limited to the following:

- a) Ball and stem made from SS-304, PTFE, RPTFE or Nylon seats, PTFE packing.
- b) Ball and stem made from SS-316, PTFE, RPTFE or Nylon seats, PTFE packing.
- c) Ball and stem made from SS-304, PTFE, RPTFE or Nylon seats and graphite stem packing suitable for fire safe design.
- d) Ball and stem made from SS-316, PTFE, RPTFE or Nylon seats and graphite stem packing suitable for fire safe design.
- e) Other trim materials could be manufactured to match with body materials.

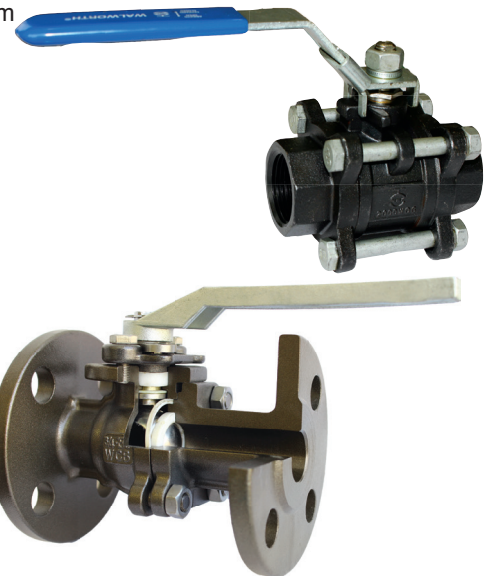

## Design Features

- Standard Floating Ball valves in accordance with API 608, API6D & MSS-SP-72 for flanged and BW ends from 1/2" up to 8". Test in accordance with API 598.
- Standard Floating Ball Valves in accordance with MSS-SP-110 for threaded and socketweld ends from 1/4" up to 4". Test in accordance with MSS-SP-110
- Fire Safe Floating Ball valves in accordance with API-6D & API-608 for flanged and BW ends from 1/2 up to 8". Test in accordance with API-598.
- Fire Safe Floating Ball valves in accordance with API-608 or ASME B16.34 for threaded and socket well ends from 1/2" up to 2". Test in accordance with API-598

## PRODUCT RANGE

| Type                            | Firesafe or Not Firesafe design | Size       | Pressure Class    | Ends                    | Figure Nr                                      |
|---------------------------------|---------------------------------|------------|-------------------|-------------------------|--|
| Two-Piece Floating Ball Valve   | Not Firesafe                    | 1/4" to 2" | 600 WOG           | Threaded                | 7711   |
| Three-Piece Floating Ball Valve | Not Firesafe                    | 1/4" to 4" | 1000 & 2000 WOG   | Threaded or Socket Weld | 7011, 7017, 7411, 7417                         |
| Two-Piece Floating Ball Valve   | Not Firesafe                    | 1/4" to 8" | 150 & 300#        | Flanged                 | 7112, 7312                                     |
| Two-Piece Floating Ball Valve   | Not Firesafe                    | 1/2" to 4" | 600#              | Flanged                 | 7612   |
| Two-Piece Floating Ball Valve   | Firesafe                        | 1/4" to 8" | 150 & 300#        | Flanged                 | 7112 Z, 7312 Z                                 |
| Two-Piece Floating Ball Valve   | Firesafe                        | 1/2" to 4" | 600#              | Flanged                 | 7612 Z   |
| Three-Piece Floating Ball Valve | Firesafe                        | 1/4" to 2" | 1500#             | Flanged                 | 7512 Z   |
| Three-Piece Floating Ball Valve | Firesafe                        | 1/4" to 2" | 800, 1500 & 2500# | Threaded or Socket Weld | 7811 Z, 7817 Z, 7511 Z, 7517 Z, 7211 Z, 7217 Z |

## STRUCTURAL FEATURES

### Lever Positions

Valves with wrench aligned with the valve is in open position, and wrench in perpendicular to the valve is in closed position.

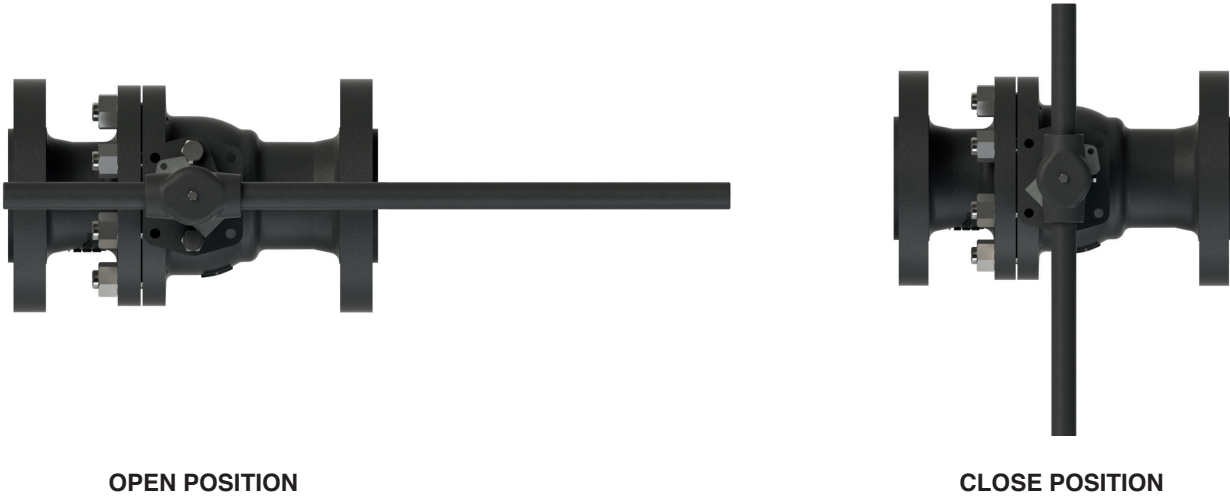

### Blow Out Proof Stem Design & Antistatic Structure

To reinforce safety, WALWORTH have fitted the product with a T-shaped blowout proof stem back seat that significantly extends stem seal life and prevents it to come out from the body structure. It also includes an antistatic device that lowers coefficient of friction between stem-ball and stem-body ball when operating the valve. Friction could cause electrostatic charges (sparks) that could cause fire when mixing with fluid. Leakage from the valve stem is prevented with the aid of two O'rings and a Gasket that work together with the graphite packing.

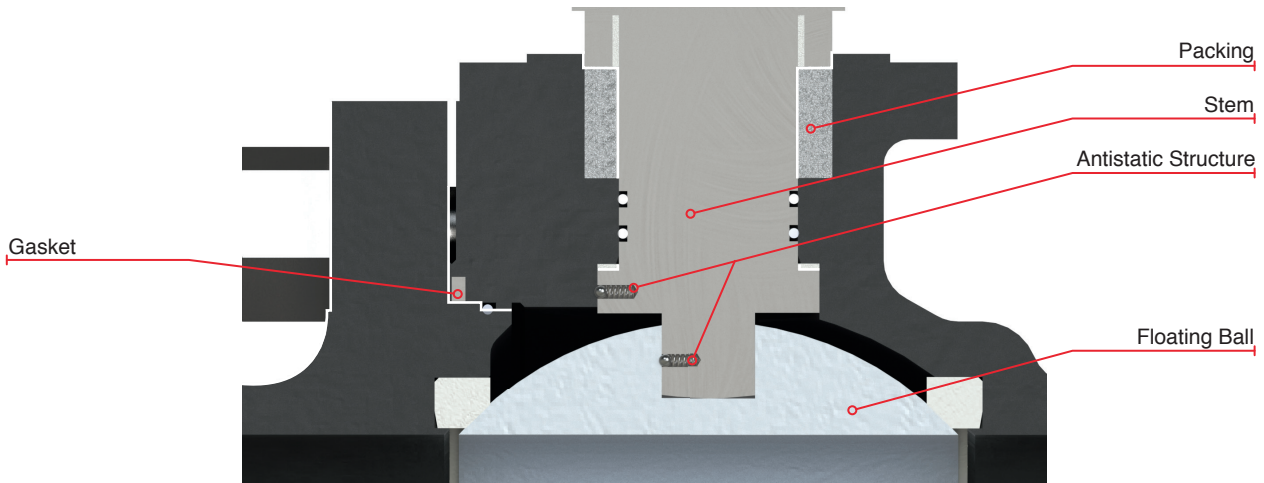

# STRUCTURAL FEATURES

## Soft Seats

Stringent limitations on ball valve designing along with operating conditions have resulted in the use of several thermoplastic materials to meet the required operating range for ball valve seat thus, WALWORTH offers soft seats such as PTFE, RPTFE, Nylon, Molon, PEEK, etc., to guarantee zero leakage in low and high pressures at different temperatures, these can be used for several services in any industry, also preferred and supplied to Oil and Gas producers. Soft seat reduce friction which result in less torque when operating the valve.

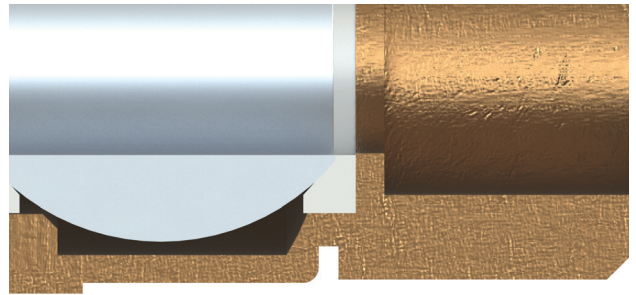

## Fire Safe Design

When a fire occurs the valve soft seal areas (packing, gasket and seat) came burnt or could be damaged, to prevent this right and left body are contacted by a gasket made of graphite instead soft seal (figure a) and the same happens on the packing stem where it is made of graphite instead soft seal (figure b). To prevent internal leakage when seat came burnt, the metal seal face of the body will act as a second seal being in contact with the ball (figure c). The design is based on the standards API 607, JB/T6899 and second part of BS6755.

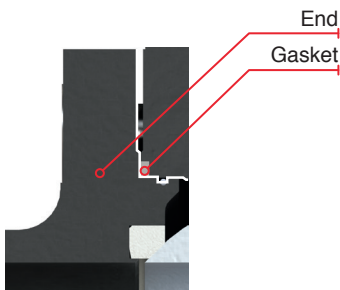

Figure a

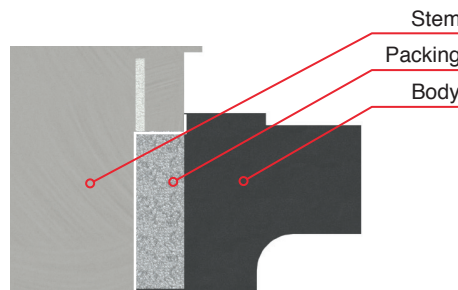

Figure b

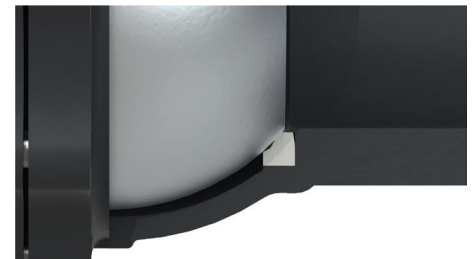
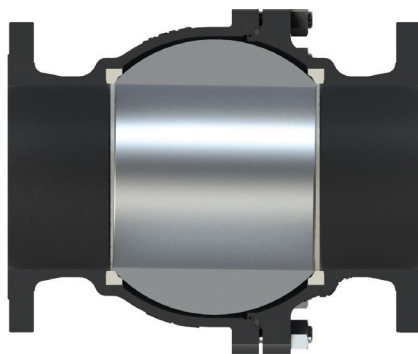

Figure c

## Full and Reduced Port

There are two types of port (full and reduced) on WALWORTH floating ball valves for different purposes. The full port design means that the port will be of the same inside diameter as the pipeline, so there will be no resistance for the fluid and this valve could be cleaned by a pig being trough conduit. Reduced port provides resistance to the fluid, the inside diameter is a size smaller than that of the pipeline being a valve not piggable



FULL PORT DESIGN

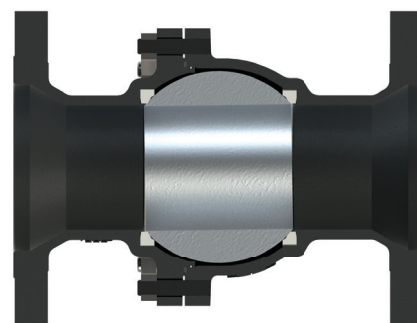

REDUCED PORT DESIGN

## WALWORTH STANDARD FLOATING BALL VALVES CLASS 600 WOG

### Design Features

- Design in accordance with MSS SP110
- CLASS 600 WOG
- Full Port
- Two-piece body
- Brass Construction
- Threaded Body
- Threaded ends as per ASME B1.20.1
- End to end dimensions as per WALWORTH standard

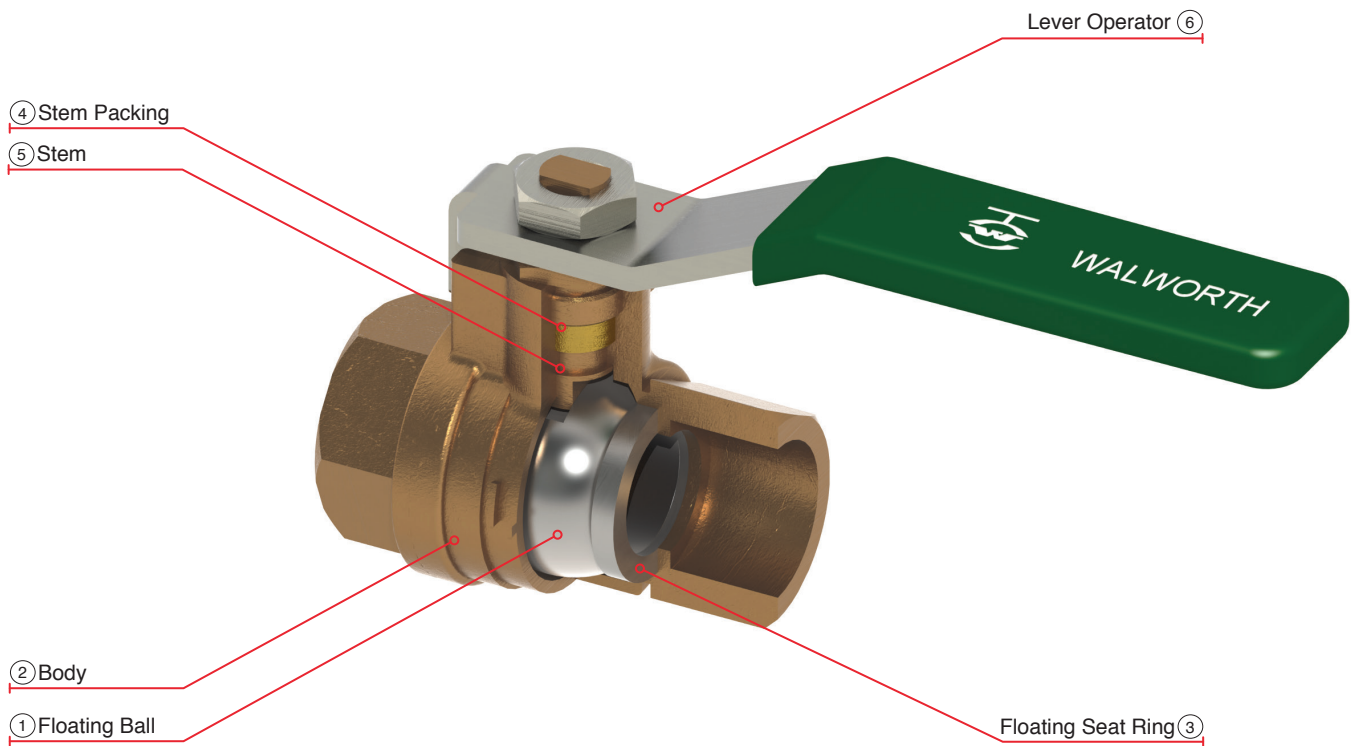

- |   |  |
|---|--|
| <p>① Floating Ball. For all sizes &amp; pressure ratings. The ball is only held by the stem and is in movement with the direction of the fluid in order to seal with the seat rings.</p> <p>② Body. Made of two pieces that includes the central body screwed with the end flanges.</p> <p>③ Floating Seat Ring. Two independent dynamic soft seat rings that get in contact with the floating ball which seal in one side of the valve depending on the fluid direction.</p> | <p>④ Stem Packing. It is a soft seal that ensure reliable operation high levels of sealing integrity when operating the valve.</p> <p>⑤ Stem. The stem design is anti blow out which is held up by the valve body and fits in the bottom with a small cavity in the top part of the floating ball.</p> <p>⑥ Lever operator. It is supplied in all sizes to open and close the valve.</p> |
|---|--|

# WALWORTH STANDARD FLOATING BALL VALVES CLASS 600 WOG

## Design Features

- Design in accordance with MSS SP110
- CLASS 600 WOG
- Full Port
- Two-piece body
- Brass Construction
- Threaded Body
- Threaded ends as per ASME B1.20.1
- End to end dimensions as per WALWORTH standard

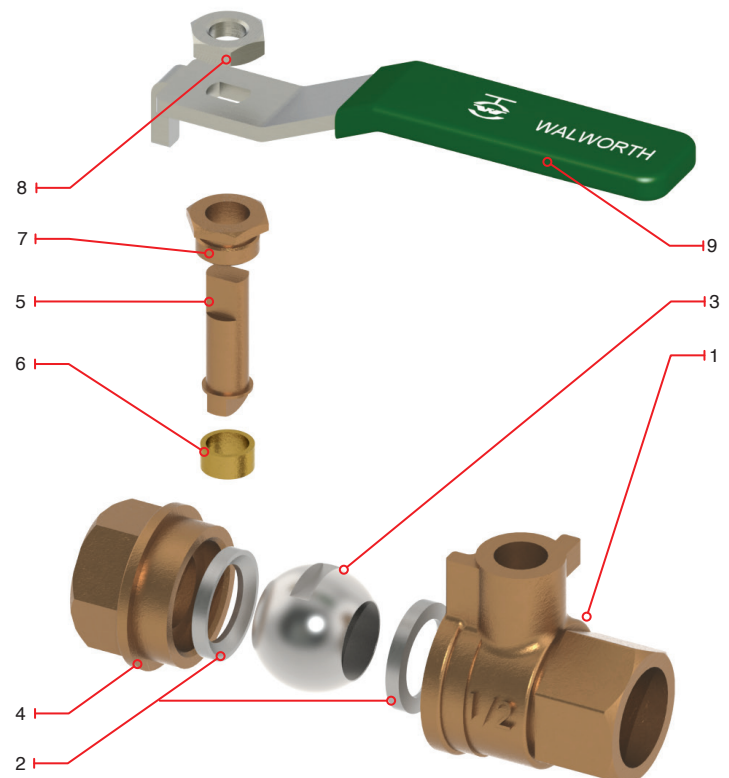

## Regular Bill of Materials

| No. | Description | Brass                                |
|-----|-------------|--------------------------------------|
| 1   | Body        | Brass B283 - C37700                  |
| 2   | Seat Ring   | PTFE                                 |
| 3   | Ball        | Brass B283 - C37700 + Chrome coating |
| 4   | End         | Brass B283 - C37700                  |
| 5   | Stem        | Brass B124 - C37700                  |
| 6   | Packing     | PTFE                                 |
| 7   | Gland       | Brass B124 - C37700                  |
| 8   | Stem Bolt   | Steel A-36 + Cadminized coating      |
| 9   | Lever       | Steel A-36 + Cadminized coating      |

# WALWORTH STANDARD FLOATING BALL VALVES

## CLASS 600 WOG

### Design Features

- Design in accordance with MSS SP110
- CLASS 600 WOG
- Full Port
- Two-piece body
- Brass Construction
- Threaded Body
- Threaded ends as per ASME B1.20.1
- End to end dimensions as per WALWORTH standard

| Lever Operator     |               |
|--------------------|---------------|
| Catalog Figure No. | Type of Ends  |
| 7711               | Threaded ends |

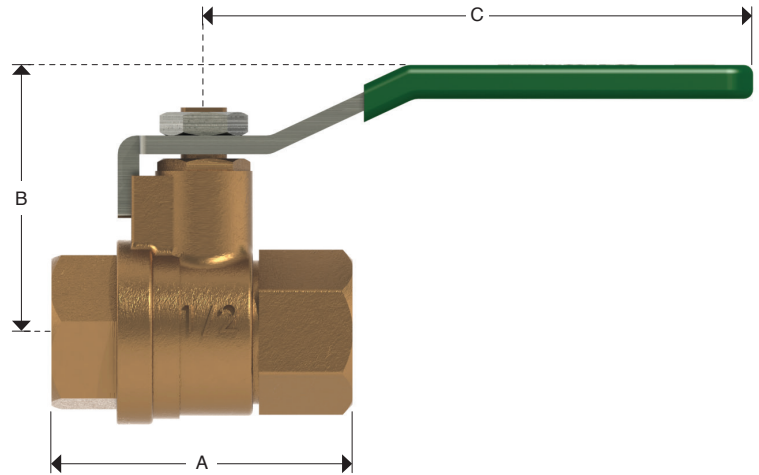

### Dimensions and Weights

| D<br>Nominal<br>Diameter | mm | 15   | 20   | 25   | 32    | 40    | 50   |
|--------------------------|----|------|------|------|-------|-------|------|
|                          | in | 1/2  | 3/4  | 1    | 1 1/4 | 1 1/2 | 2    |
| A                        | mm | 57   | 67   | 77   | 92    | 103   | 122  |
|                          | in | 2.24 | 2.64 | 3.03 | 3.62  | 4.05  | 4.8  |
| B                        | mm | 39   | 57   | 65   | 71    | 140   | 140  |
|                          | in | 1.53 | 2.24 | 2.56 | 2.79  | 5.51  | 5.51 |
| C                        | mm | 90   | 90   | 125  | 125   | 140   | 140  |
|                          | in | 3.54 | 3.54 | 4.92 | 4.92  | 5.51  | 5.51 |
| Weight<br>7711           | kg | 0.22 | 0.34 | 0.57 | 0.85  | 1.37  | 2.08 |
|                          | lb | 0.49 | 0.75 | 1.26 | 1.87  | 3.02  | 4.59 |

Note: Dimensions not regulated per norm, only for illustrative purposes, they can change without previous notice.

# WALWORTH STANDARD FLOATING BALL VALVES CLASS 1000 WOG & 2000 WOG

## Design Features

- Design in accordance with MSS SP110
- CLASS 1000 WOG & 2000 WOG
- Full Port
- Three-piece body
- Investment Cast Steel Construction
- Bolted Body
- Threaded ends as per ASME B1.20.1
- Socket weld ends as per ASME B16.11
- End to end dimensions as per WALWORTH standard

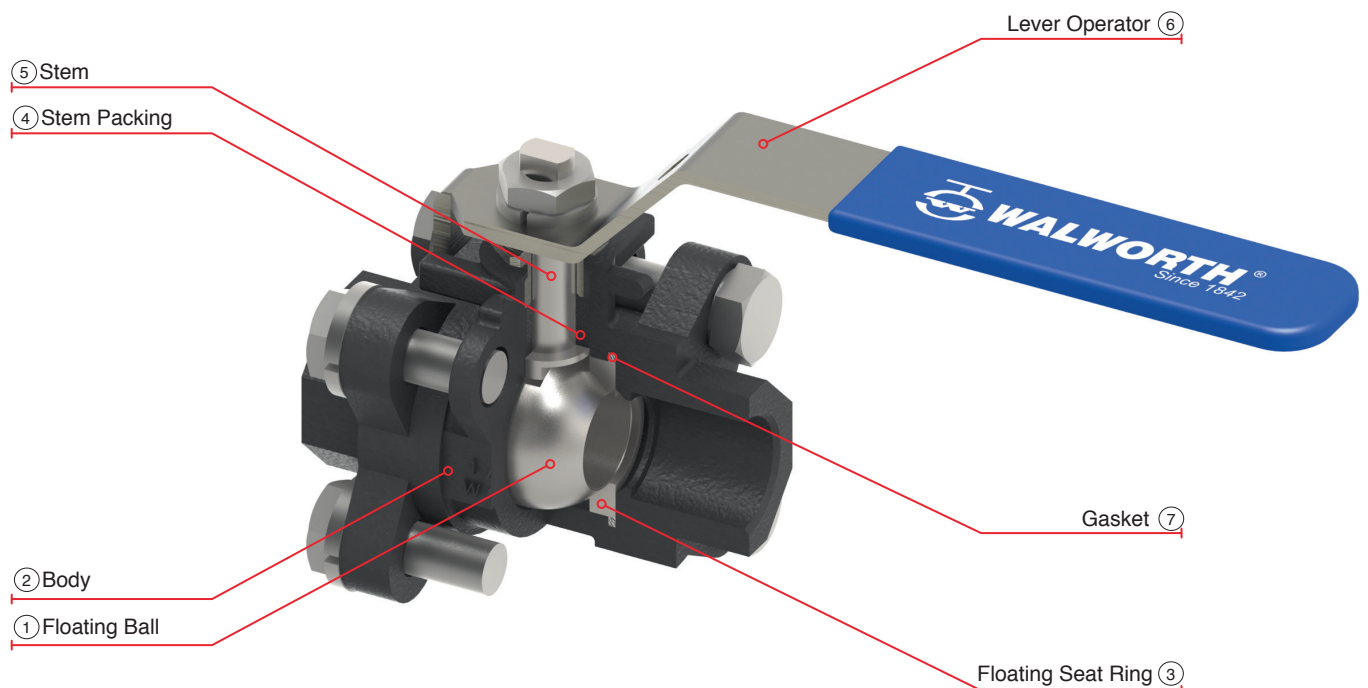

- ① Floating Ball. For all sizes & pressure ratings. The ball is only hold by the stem and is in movement with the direction of the fluid in order to seal with the seat rings.
- ② Body. Made of three pieces that includes the central body bolted with the end flanges.
- ③ Floating Seat Ring. Two independent dynamic soft seat rings that get in contact with the floating ball which seal in one side of the valve depending on the fluid direction.
- ④ Stem Packing. It is a soft seal that ensure reliable operation high levels of sealing integrity when operating the valve.
- ⑤ Stem. The stem design is anti blow out which is held up by the valve body and fits in the bottom with a small cavity in the top part of the floating ball.
- ⑥ Lever operator. It is supplied in all sizes to open and close the valve.
- ⑦ Gasket. It is a soft seal that has a reliable operation with high levels of sealing integrity between body and ends.

# WALWORTH STANDARD FLOATING BALL VALVES

## CLASS 1000 WOG & 2000 WOG

### Design Features

- Design in accordance with MSS SP110
- CLASS 1000 WOG & 2000 WOG
- Full Port
- Three-piece body
- Investment Cast Steel Construction
- Bolted Body
- Threaded ends as per ASME B1.20.1
- Socket weld ends as per ASME B16.11
- End to end dimensions as per WALWORTH standard

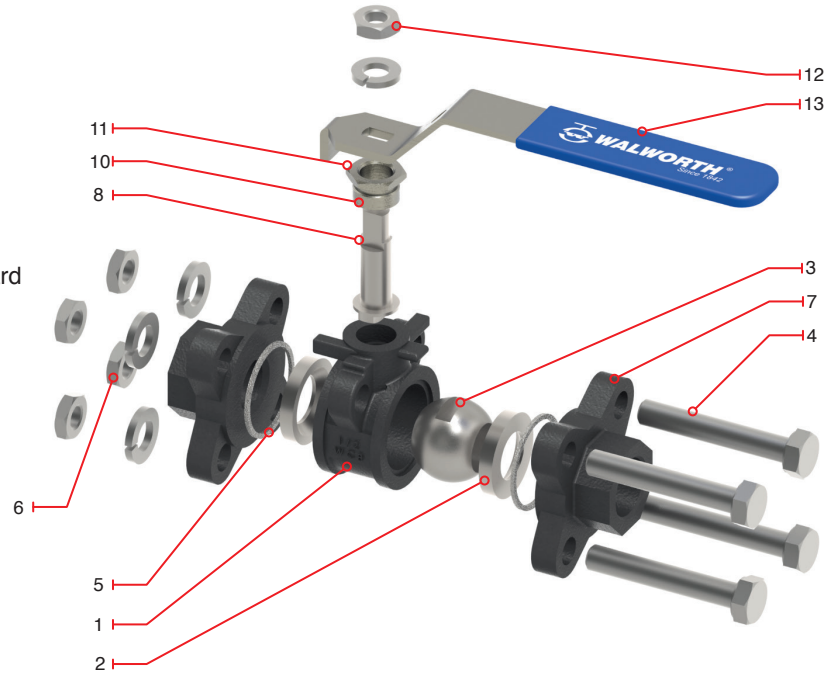

### Regular Bill of Materials

| No. | Description          | Carbon Steel with Trim F4 (SS304) | Stainless Steel 316 | Carbon Steel Trim F4 (SS304) NACE | Stainless Steel 316 with Trim F3 (SS316) NACE |
|-----|----------------------|-----------------------------------|---------------------|-----------------------------------|---|
| 1   | Body                 | ASTM A216 GR WCB                  | ASTM A351 GR CF8M   | ASTM A216 GR WCB                  | ASTM A351 GR CF8M                             |
| 2   | Seat Ring            | PTFE + Graphite                   |                     |                                   |   |
| 3   | Ball                 | SS304                             | SS316               | SS304                             | SS316   |
| 4   | Stud                 | ASTM A193 Gr. B7                  | ASTM A193 Gr. B8    | ASTM A193 Gr. B7M                 | ASTM A193 Gr. B8M                             |
| 5   | Gasket               | PTFE                              |                     |                                   |   |
| 6   | Nut                  | ASTM A194 Gr. 2H                  | ASTM A194 Gr. 8     | ASTM A194 Gr. 2HM                 | ASTM A194 Gr. 8M                              |
| 7   | End                  | ASTM A216 GR WCB                  | ASTM A351 GR CF8M   | ASTM A216 GR WCB                  | ASTM A351 GR CF8M                             |
| 8   | Stem                 | ASTM A182 Gr. F304                | ASTM A182 Gr. F316  | ASTM A182 Gr. F304                | ASTM A182 Gr. F316                            |
| *9  | Stem Seat            | PTFE                              |                     |                                   |   |
| 10  | Packing              | PTFE                              |                     |                                   |   |
| 11  | Packing Gland        | ASTM A216 GR WCB OR SS304         | SS304               | ASTM A216 GR WCB OR SS304         | SS304   |
| 12  | Stem Nut             | ASTM A194 Gr. 2H                  | ASTM A194 Gr. 8     | ASTM A194 Gr. 2HM                 | ASTM A194 Gr. 8M                              |
| 13  | Lever                | ASTM A216 GR WCB                  |                     |                                   |   |
| *14 | Identification Plate | Stainless Steel                   | Stainless Steel     | Stainless Steel                   | Stainless Steel                               |

\* Not Shown

# WALWORTH STANDARD FLOATING BALL VALVES CLASS 1000 WOG

## Design Features

- Design in accordance with MSS SP110
- CLASS 1000 WOG
- Full Port
- Three-pieces body
- Investment Cast Steel Construction
- Bolted Body
- Threaded ends as per ASME B1.20.1
- Socket weld ends as per ASME B16.11
- End to end dimensions as per WALWORTH standard

| Lever Operator     |                  |
|--------------------|------------------|
| Catalog Figure No. | Type of Ends     |
| 7011               | Threaded (S)     |
| 7017               | Socket Weld (SW) |

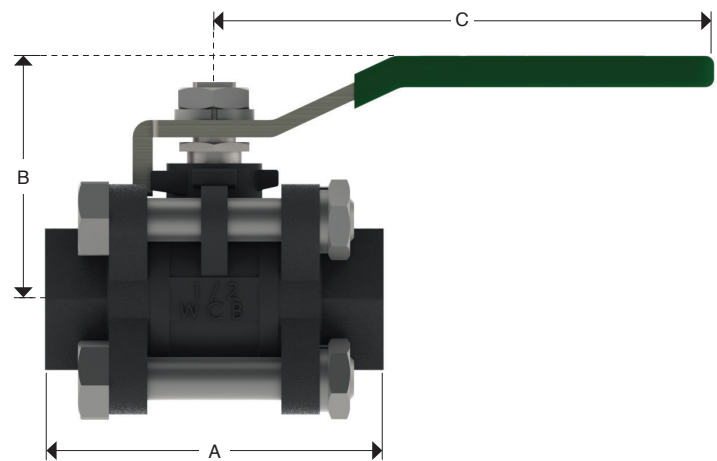

## Dimensions and Weights

| D<br>Nominal<br>Diameter | mm | 6     | 10    | 15    | 20    | 25    | 32    | 40    | 50    | 65    | 80    | 100    |
|--------------------------|----|-------|-------|-------|-------|-------|-------|-------|-------|-------|-------|--------|
|                          | in | 1/4   | 3/8   | 1/2   | 3/4   | 1     | 1 1/4 | 1 1/2 | 2     | 2 1/2 | 3     | 4      |
| A                        | mm | 50.4  | 50.4  | 61.4  | 70.2  | 79.6  | 93    | 102   | 124.2 | 156.2 | 179.2 | 218.4  |
|                          | in | 2     | 2     | 2 3/7 | 2 3/4 | 3 1/7 | 3 2/3 | 4     | 4 8/9 | 6 1/7 | 7     | 8 3/5  |
| B                        | mm | 42.5  | 42.5  | 49.6  | 58.1  | 61    | 78.3  | 82.5  | 90.9  | 114.5 | 124   | 176    |
|                          | in | 1 2/3 | 1 2/3 | 2     | 2 2/7 | 2 2/5 | 3     | 3 1/4 | 3 4/7 | 4 1/2 | 4 7/8 | 7      |
| C                        | mm | 101.5 | 101.5 | 101.5 | 124   | 124   | 152   | 152   | 190   | 242   | 242   | 327    |
|                          | in | 4     | 4     | 4     | 4 7/8 | 4 7/8 | 6     | 6     | 7 1/2 | 9 1/2 | 9 1/2 | 12 7/8 |
| Weight<br>7011           | kg | 0.41  | 0.41  | 0.46  | 0.87  | 1.09  | 1.93  | 2.6   | 3.75  | 9.1   | 13.23 | 20.63  |
|                          | lb | 0.90  | 0.90  | 1.01  | 1.92  | 2.40  | 4.26  | 5.73  | 8.27  | 20.07 | 29.17 | 45.49  |

# WALWORTH STANDARD FLOATING BALL VALVES CLASS 2000 WOG

## Design Features

- Design in accordance with MSS SP110
- CLASS 2000 WOG
- Full Port
- Three-pieces body
- Investment Cast Steel Construction
- Bolted Body
- Threaded ends as per ASME B1.20.1
- Socket weld ends as per ASME B16.11
- End to end dimensions as per WALWORTH standard

| Lever Operator     |                  |
|--------------------|------------------|
| Catalog Figure No. | Type of Ends     |
| 7411               | Threaded (S)     |
| 7417               | Socket Weld (SW) |

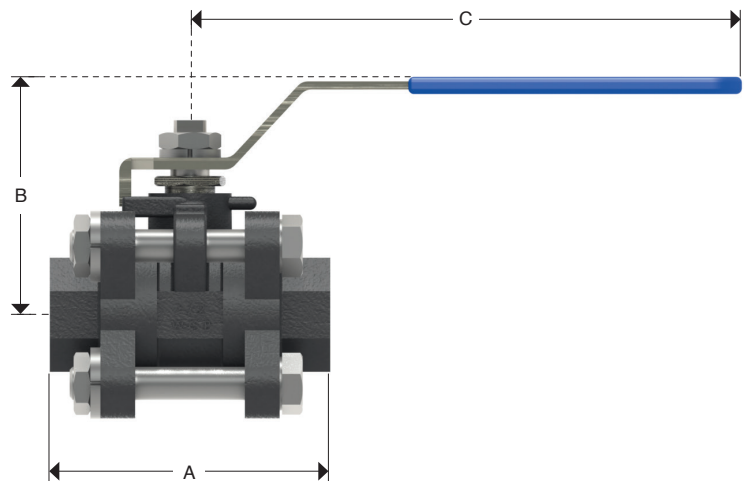

## Dimensions and Weights

| D<br>Nominal<br>Diameter | mm | 6     | 10    | 15    | 20    | 25    | 32    | 40    | 50    |
|--------------------------|----|-------|-------|-------|-------|-------|-------|-------|-------|
|                          | in | 1/4   | 3/8   | 1/2   | 3/4   | 1     | 1 1/4 | 1 1/2 | 2     |
| A                        | mm | 63    | 63    | 66    | 83    | 95    | 106.6 | 130   | 150.6 |
|                          | in | 2 1/2 | 2 1/2 | 2 3/5 | 3 1/4 | 3 3/4 | 4 1/5 | 5 1/8 | 6     |
| B                        | mm | 54    | 54    | 59    | 63    | 76    | 85    | 91    | 100   |
|                          | in | 2 1/8 | 2 1/8 | 2 1/3 | 2 1/2 | 3     | 3 1/3 | 3 4/7 | 4     |
| C                        | mm | 104   | 104   | 125   | 125   | 155   | 155   | 200   | 200   |
|                          | in | 4     | 4     | 5     | 5     | 6 1/9 | 6 1/9 | 7 7/8 | 7 7/8 |
| Weight<br>7411           | kg | 0.47  | 0.45  | 0.64  | 0.89  | 1.27  | 1.99  | 2.91  | 4.39  |
|                          | lb | 1.04  | 0.99  | 1.41  | 1.96  | 2.80  | 4.39  | 6.42  | 9.68  |

Note: Dimensions not regulated per norm, only for illustrative purposes, they can change without previous notice.

# WALWORTH STANDARD FLOATING BALL VALVES

## CLASS 150, 300 & 600

### Design Features

- Design in accordance with MSS SP-72, API-608 & API-6D
- CLASS 150, 300 & 600 as per ASME B16.34
- Full Port
- Two-piece body
- Cast Steel Construction
- Bolted Body
- Flanged ends as per ASME B16.5
- End to end dimensions as per ASME B16.10
- Butt Weld ends as per ASME B16.25
- Gear Operator (Optional)
- Valves could be supplied with ISO-5211 flange for operator installation (optional)



- ① Floating Ball. For all sizes & pressure ratings. The ball is only hold by the stem and is in movement with the direction of the fluid in order to seal with the seat rings.
- ② Body. Made of two pieces that includes the central body bolted with the end flange.
- ③ Floating Seat Ring. Two independent dynamic soft seat rings that get in contact with the floating ball which seal in one side of the valve depending on the fluid direction.
- ④ Stem Packing. It is a soft seal that ensure reliable operation high levels of sealing integrity when operating the valve.
- ⑤ Stem. The stem design is anti blow out and with an antistatic structure which is held up by the valve body and fits in the bottom in a small cavity in the top part of the floating ball.
- ⑥ Lever operator. It is supplied in all sizes to open and close the valve.
- ⑦ Gasket. It is a soft seal that has a reliable operation with high levels of sealing integrity between body and ends.
- ⑧ Antistatic device. Inconel springs with small balls are placed between stem-body and stem-floating ball to prevent static continuity.

# WALWORTH STANDARD FLOATING BALL VALVES

## CLASS 150, 300 & 600

### Design Features

- Design in accordance with MSS SP-72, API-608 & API-6D
- CLASS 150, 300 & 600 as per ASME B16.34
- Full Port
- Two-piece body
- Cast Steel Construction
- Bolted Body
- Flanged ends as per ASME B16.5
- End to end dimensions as per ASME B16.10
- Butt Weld ends as per ASME B16.25
- Gear Operator (Optional)
- Valves could be supplied with ISO-5211 flange for operator installation (optional)

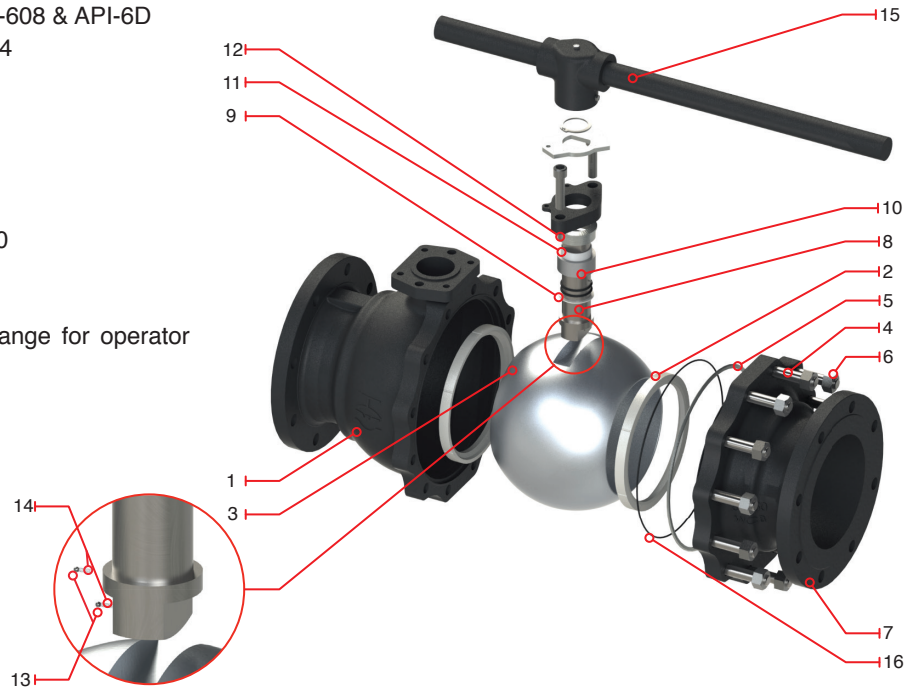

### Regular Bill of Materials

| No. | Description          | Carbon Steel with Trim F4 (SS304)           | Carbon Steel with Trim F3 (SS316) | Stainless Steel 316 | Carbon Steel with Trim F4 (SS304) NACE | Stainless Steel 316 with Trim F3 (SS316) NACE |
|-----|----------------------|---|-----------------------------------|---------------------|--|---|
| 1   | Body                 | ASTM A216 GR WCB                            | ASTM A216 GR WCB                  | ASTM A351 GR CF8M   | ASTM A216 GR WCB                       | ASTM A351 GR CF8M                             |
| 2   | Seat Ring            | RPTFE, PTFE or Nylon**                      |                                   |                     |  |   |
| 3   | Ball                 | ASTM A182 Gr. F304                          | ASTM A182 Gr. F316                | ASTM A182 Gr. F316  | ASTM A182 Gr. F304                     | ASTM A182 Gr. F316                            |
| 4   | Stud                 | ASTM A193 Gr. B7                            | ASTM A193 Gr. B7                  | ASTM A193 Gr. B8    | ASTM A193 Gr. B7M                      | ASTM A193 Gr. B8M                             |
| 5   | Gasket               | PTFE or Flexible Graphite + Stainless Steel |                                   |                     |  |   |
| 6   | Nut                  | ASTM A194 Gr. 2H                            | ASTM A194 Gr. 2H                  | ASTM A194 Gr. 8     | ASTM A194 Gr. 2HM                      | ASTM A194 Gr. 8M                              |
| 7   | End                  | ASTM A216 GR WCB                            | ASTM A216 GR WCB                  | ASTM A351 GR CF8M   | ASTM A216 GR WCB                       | ASTM A351 GR CF8M                             |
| 8   | Stem                 | ASTM A182 Gr. F304                          | ASTM A182 Gr. F304                | ASTM A182 Gr. F316  | ASTM A182 Gr. F304                     | ASTM A182 Gr. F316                            |
| 9   | Stem Seat            | PTFE or RPTFE                               |                                   |                     |  |   |
| 10  | Packing              | PTFE or Graphite                            |                                   |                     |  |   |
| 11  | Gland                | ASTM A182 Gr. F304                          | ASTM A182 Gr. F316                | ASTM A182 Gr. F316  | ASTM A182 Gr. F304                     | ASTM A182 Gr. F316                            |
| 12  | Gland Flange         | ASTM A216 GR WCB                            | ASTM A216 GR WCB                  | ASTM A351 GR CF8M   | ASTM A216 GR WCB                       | ASTM A351 GR CF8M                             |
| 13  | Small ball           | Stainless Steel                             |                                   |                     |  |   |
| 14  | Antistatic spring    | Inconel 750                                 |                                   |                     |  |   |
| 15  | Lever                | Carbon Steel                                |                                   |                     |  |   |
| 16  | Backup O'ring        | Viton                                       |                                   |                     |  |   |
| *17 | Identification Plate | Stainless Steel                             |                                   |                     |  |   |

\* Not Shown

\*\* Material used as standard on Class 600

# WALWORTH STANDARD FLOATING BALL VALVES CLASS 150

## Design Features

- Design in accordance with MSS SP-72, API-608 & API-6D
- CLASS 150 as per ASME B16.34
- Full Port
- Two-piece body
- Cast Steel Construction
- Bolted Body
- Flanged ends as per ASME B16.5
- End to end dimensions as per ASME B16.10
- Butt Weld ends as per ASME B16.25
- Gear Operator 6" and larger (Optional)
- Valves could be supplied with ISO-5211 flange for operator installation (optional)

| Lever Operator     |                         |
|--------------------|-------------------------|
| Catalog Figure No. | Type of Ends            |
| 7112               | Flanged Raised Face     |
| 7113               | Flanged Ring Type Joint |
| 7114               | Butt Weld               |

| Gear Operator      |                         |
|--------------------|-------------------------|
| Catalog Figure No. | Type of Ends            |
| 7122               | Flanged Raised Face     |
| 7123               | Flanged Ring Type Joint |
| 7124               | Butt Weld               |

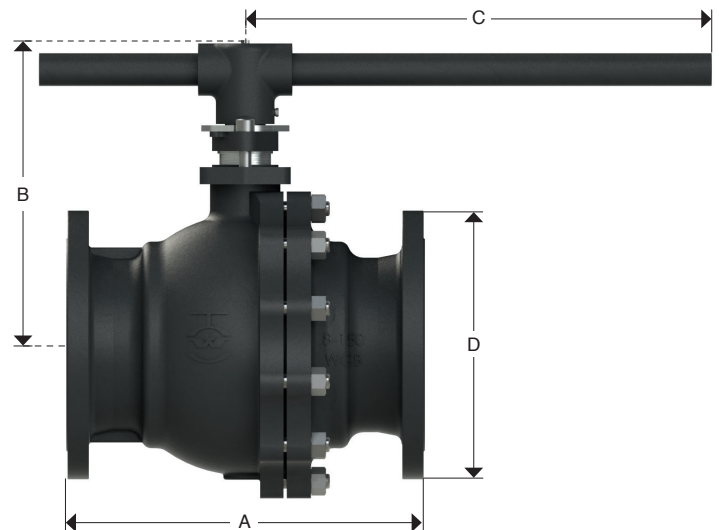

## Dimensions and Weights

| D<br>Nominal<br>Diameter | mm | 15    | 20    | 25    | 32    | 40    | 50    | 65    | 80     | 100    | 150    | 200    |
|--------------------------|----|-------|-------|-------|-------|-------|-------|-------|--------|--------|--------|--------|
|                          | in | 1/2   | 3/4   | 1     | 1 1/4 | 1 1/2 | 2     | 2 1/2 | 3      | 4      | 6      | 8      |
| A<br>(RF)                | mm | 108   | 117   | 127   | 140   | 165   | 178   | 190   | 203    | 229    | 394    | 457    |
|                          | in | 4 1/4 | 4 3/5 | 5     | 5 1/2 | 6 1/2 | 7     | 7 1/2 | 8      | 9      | 15 1/2 | 18     |
| D                        | mm | 89    | 98    | 108   | 117   | 127   | 152   | 178   | 190    | 229    | 279    | 343    |
|                          | in | 3 1/2 | 3 6/7 | 4 1/4 | 4 3/5 | 5     | 6     | 7     | 7 1/2  | 9      | 11     | 13 1/2 |
| B                        | mm | 73    | 76    | 86    | 91    | 119   | 127   | 136   | 164    | 178    | 303    | 352    |
|                          | in | 2 7/8 | 3     | 3 2/5 | 3 4/7 | 4 2/3 | 5     | 5 1/3 | 6 1/2  | 7      | 12     | 13 6/7 |
| C                        | mm | 130   | 130   | 160   | 160   | 200   | 200   | 200   | 325    | 325    | 800    | 800    |
|                          | in | 5 1/8 | 5 1/8 | 6 2/7 | 6 2/7 | 7 7/8 | 7 7/8 | 7 7/8 | 12 4/5 | 12 4/5 | 31 1/2 | 31 1/2 |
| Weight<br>7112           | kg | 1.5   | 2     | 3     | 4     | 6     | 8     | 15    | 19     | 31     | 82     | 145    |
|                          | lb | 3.31  | 4.41  | 6.62  | 8.82  | 13.23 | 17.64 | 33.08 | 41.90  | 68.36  | 180.82 | 319.74 |

# WALWORTH STANDARD FLOATING BALL VALVES CLASS 300

## Design Features

- Design in accordance with MSS SP-72, API-608 & API-6D
- CLASS 300 As per ASME B16.34
- Full Port
- Two-piece body
- Cast Steel Construction
- Bolted Body
- Flanged ends as per ASME B16.5
- End to end dimensions as per ASME B16.10
- Butt Weld ends as per ASME B16.25
- Gear Operator 6" and larger (Optional)
- Valves could be supplied with ISO-5211 flange for operator installation (optional)

| Lever Operator     |                         |
|--------------------|-------------------------|
| Catalog Figure No. | Type of Ends            |
| 7312               | Flanged Raised Face     |
| 7313               | Flanged Ring Type Joint |
| 7314               | Butt Weld               |

| Gear Operator      |                         |
|--------------------|-------------------------|
| Catalog Figure No. | Type of Ends            |
| 7322               | Flanged Raised Face     |
| 7323               | Flanged Ring Type Joint |
| 7324               | Butt Weld               |

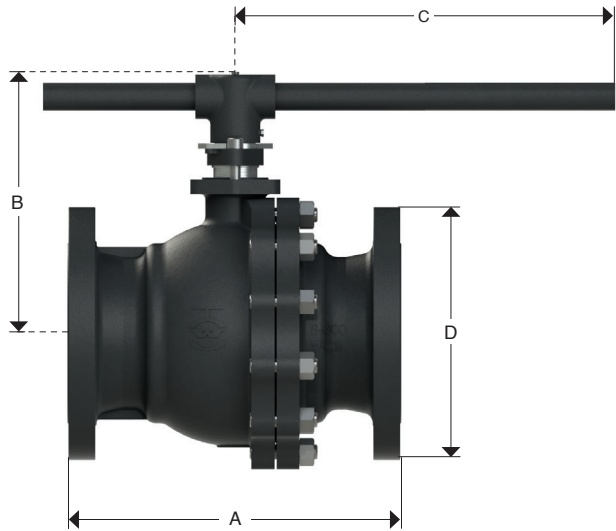

## Dimensions and Weights

| D<br>Nominal<br>Diameter | mm | 15    | 20    | 25    | 40    | 50    | 65     | 80     | 100    | 150    | 200    |
|--------------------------|----|-------|-------|-------|-------|-------|--------|--------|--------|--------|--------|
|                          | in | 1/2   | 3/4   | 1     | 1 1/2 | 2     | 2 1/2  | 3      | 4      | 6      | 8      |
| A<br>(RF)                | mm | 140   | 152   | 165   | 191   | 216   | 241    | 283    | 305    | 403    | 502    |
|                          | in | 5 1/2 | 6     | 6 1/2 | 7 1/2 | 8 1/2 | 9 1/2  | 11 1/7 | 12     | 15 6/7 | 19 3/4 |
| D                        | mm | 95    | 117   | 124   | 156   | 165   | 190    | 210    | 254    | 318    | 381    |
|                          | in | 3 3/4 | 4 3/5 | 4 7/8 | 6 1/7 | 6 1/2 | 7 1/2  | 8 1/4  | 10     | 12 1/2 | 15     |
| B                        | mm | 72    | 92    | 105   | 125   | 135   | 153    | 172    | 210    | 303    | 357    |
|                          | in | 2 5/6 | 3 5/8 | 4 1/7 | 5     | 5 1/3 | 6      | 6 7/9  | 8 1/4  | 12     | 14     |
| C                        | mm | 160   | 160   | 160   | 180   | 230   | 400    | 400    | 400    | 800    | 1000   |
|                          | in | 6 2/7 | 6 2/7 | 6 2/7 | 7     | 9     | 15 3/4 | 15 3/4 | 15 3/4 | 31 1/2 | 39 3/8 |
| Weight<br>7312           | kg | 3     | 5     | 6     | 11    | 16    | 24     | 34     | 56     | 125    | 222    |
|                          | lb | 6.62  | 11.03 | 13.23 | 24.26 | 35.28 | 52.92  | 74.97  | 123.48 | 275.63 | 489.53 |

Note: Dimensions not regulated per norm, only for illustrative purposes, they can change without previous notice.

# WALWORTH STANDARD FLOATING BALL VALVES CLASS 600

## Design Features

- Design in accordance with MSS SP-72, API-608 & API-6D
- CLASS 600 as per ASME B16.34
- Full Port
- Two-piece body
- Cast Steel Construction
- Bolted Body
- Flanged ends as per ASME B16.5
- End to end dimensions as per ASME B16.10
- Butt Weld ends as per ASME B16.25
- Gear Operator 4" and larger (Optional)
- Valves could be supplied with ISO-5211 flange for operator installation (optional)

| Lever Operator     |                         |
|--------------------|-------------------------|
| Catalog Figure No. | Type of Ends            |
| 7612               | Flanged Raised Face     |
| 7613               | Flanged Ring Type Joint |
| 7614               | Butt Weld               |

| Gear Operator      |                         |
|--------------------|-------------------------|
| Catalog Figure No. | Type of Ends            |
| 7622               | Flanged Raised Face     |
| 7623               | Flanged Ring Type Joint |
| 7624               | Butt Weld               |

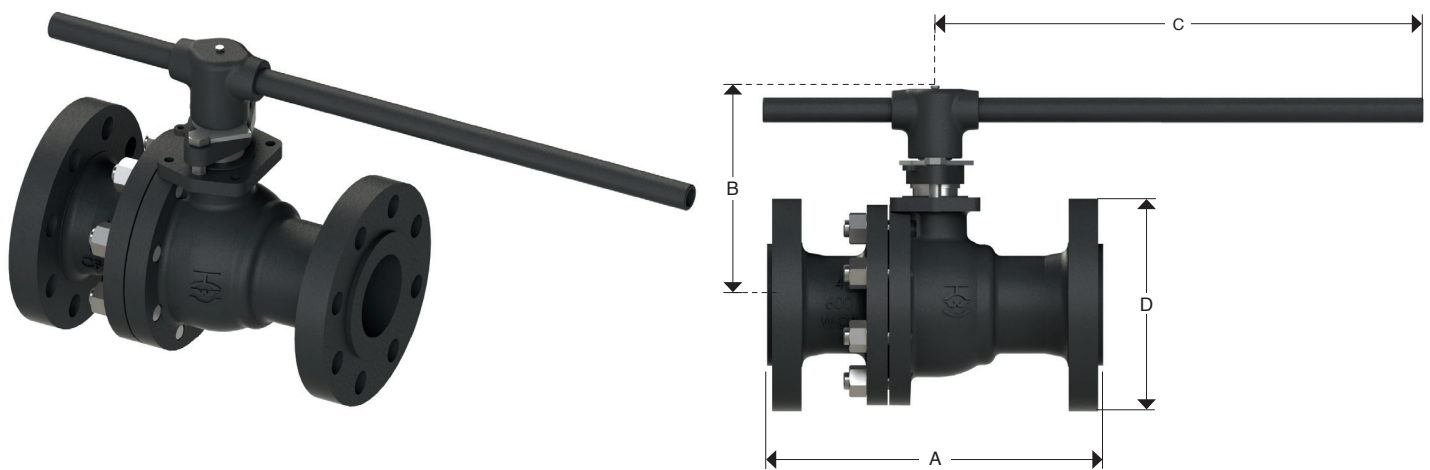

## Dimensions and Weights

| D<br>Nominal<br>Diameter | mm | 15    | 20    | 25    | 40    | 50     | 65     | 80     | 100    |
|--------------------------|----|-------|-------|-------|-------|--------|--------|--------|--------|
|                          | in | 1/2   | 3/4   | 1     | 1 1/2 | 2      | 2 1/2  | 3      | 4      |
| A<br>(RF)                | mm | 165   | 190   | 216   | 241   | 292    | 330    | 356    | 432    |
|                          | in | 6 1/2 | 7 1/2 | 8 1/2 | 9 1/2 | 11 1/2 | 13     | 14     | 17     |
| D                        | mm | 95    | 117   | 124   | 156   | 165    | 190    | 210    | 273    |
|                          | in | 3 3/4 | 4 3/5 | 4 7/8 | 6 1/7 | 6 1/2  | 7 1/2  | 8 1/4  | 10 3/4 |
| B                        | mm | 72    | 95    | 110   | 130   | 142    | 180    | 200    | 245    |
|                          | in | 2 5/6 | 3 3/4 | 4 1/3 | 5 1/8 | 5 3/5  | 7      | 7 7/8  | 9 2/3  |
| C                        | mm | 160   | 160   | 230   | 230   | 400    | 400    | 500    | 800    |
|                          | in | 6 2/7 | 6 2/7 | 9     | 9     | 15 3/4 | 15 3/4 | 19 2/3 | 31 1/2 |
| Weight<br>7612           | kg | 5     | 7     | 9     | 17    | 25     | 42     | 56     | 85     |
|                          | lb | 11.03 | 15.44 | 19.85 | 37.49 | 55.13  | 92.61  | 123.48 | 187.43 |

Note: Dimensions not regulated per norm, only for illustrative purposes, they can change without previous notice.

# WALWORTH FIRE SAFE FLOATING BALL VALVES

## CLASS 150, 300 & 600

### Design Features

- Design in accordance with API 6D & API 608
- CLASS 150, 300 & 600 as per ASME B16.34
- Full Port
- Reduced Port (upon request)
- Two-piece body
- Fire safe design as per API 6FA, API 607
- Cast Steel Construction
- Bolted Body
- Flanged ends as per ASME B16.5
- End to end dimensions as per ASME B16.10
- Butt Weld ends as per ASME B16.25
- Gear Operator (Optional)
- Valves could be supplied with ISO-5211 flange for operator installation (optional)



- ① Floating Ball. For all sizes & pressure ratings. The ball is only hold by the stem and is in movement with the direction of the fluid in order to seal with the seat rings.
- ② Body. Made of two pieces that includes the central body bolted with the end flange.
- ③ Floating Seat Ring. Two independent dynamic soft seat rings that get in contact with the floating ball which seal in one side of the valve depending on the fluid direction.
- ④ Stem Packing (firesafe design). It is a graphite seal that ensure safety for fire emergency as it has a reliable operation with high levels of sealing integrity when operating the valve.
- ⑤ Stem. The stem design is anti blow out and with an antistatic structure which is held up by the valve body and fits in the bottom in a small cavity in the top part of the floating ball.
- ⑥ Lever operator. It is supplied in all sizes to open and close the valve.
- ⑦ Gasket (firesafe design). It is a graphite seal that ensure safety for fire emergency as it has a reliable operation with high levels of sealing integrity between body and ends.
- ⑧ Antistatic device. Inconel springs with small balls are placed between stem-body and stem-floating ball to prevent static continuity.

# WALWORTH FIRE SAFE FLOATING BALL VALVES

## CLASS 150, 300 & 600

### Design Features

- Design in accordance with API-6D & API 608
- CLASS 150, 300 & 600 as per ASME B16.34
- Full Port
- Reduced Port (upon request)
- Two-piece body
- Fire safe design as per API 607
- Cast Steel Construction
- Bolted Body
- Flanged ends as per ASME B16.5
- End to end dimensions as per ASME B16.10
- Butt Weld ends as per ASME B16.25
- Gear Operator (Optional)
- Valves could be supplied with ISO-5211 flange for operator installation (optional)

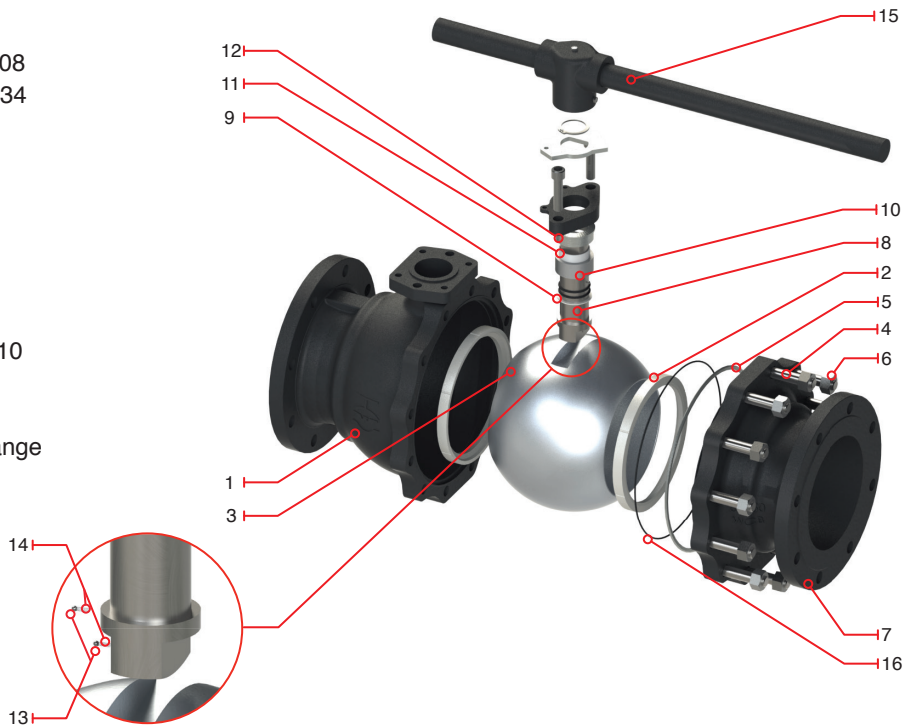

### Regular Bill of Materials

| No. | Description          | Carbon Steel with Trim F4 (SS304)   | Carbon Steel with Trim F3 (SS316) | Stainless Steel 316 | Carbon Steel with Trim F4 (SS304) NACE | Stainless Steel 316 with Trim F3 (SS316) NACE |
|-----|----------------------|-------------------------------------|-----------------------------------|---------------------|--|---|
| 1   | Body                 | ASTM A216 GR WCB                    | ASTM A216 GR WCB                  | ASTM A351 GR CF8M   | ASTM A216 GR WCB                       | ASTM A351 GR CF8M                             |
| 2   | Seat Ring            | RPTFE, PTFE or Nylon**              |                                   |                     |  |   |
| 3   | Ball                 | ASTM A182 Gr. F304                  | ASTM A182 Gr. F316                | ASTM A182 Gr. F316  | ASTM A182 Gr. F304                     | ASTM A182 Gr. F316                            |
| 4   | Stud                 | ASTM A193 Gr. B7                    | ASTM A193 Gr. B7                  | ASTM A193 Gr. B8    | ASTM A193 Gr. B7M                      | ASTM A193 Gr. B8M                             |
| 5   | Gasket               | Flexible Graphite + Stainless Steel |                                   |                     |  |   |
| 6   | Nut                  | ASTM A194 Gr. 2H                    | ASTM A194 Gr. 2H                  | ASTM A194 Gr. 8     | ASTM A194 Gr. 2HM                      | ASTM A194 Gr. 8M                              |
| 7   | End                  | ASTM A216 GR WCB                    | ASTM A216 GR WCB                  | ASTM A351 GR CF8M   | ASTM A216 GR WCB                       | ASTM A351 GR CF8M                             |
| 8   | Stem                 | ASTM A182 Gr. F304                  | ASTM A182 Gr. F304                | ASTM A182 Gr. F316  | ASTM A182 Gr. F304                     | ASTM A182 Gr. F316                            |
| 9   | Stem Seat            | PTFE or RPTFE                       |                                   |                     |  |   |
| 10  | Packing              | Graphite                            |                                   |                     |  |   |
| 11  | Gland                | ASTM A182 Gr. F304                  | ASTM A182 Gr. F316                | ASTM A182 Gr. F316  | ASTM A182 Gr. F304                     | ASTM A182 Gr. F316                            |
| 12  | Gland Flange         | ASTM A216 GR WCB                    | ASTM A216 GR WCB                  | ASTM A351 GR CF8M   | ASTM A216 GR WCB                       | ASTM A351 GR CF8M                             |
| 13  | Small ball           | Stainless Steel                     |                                   |                     |  |   |
| 14  | Antistatic spring    | Inconel 750                         |                                   |                     |  |   |
| 15  | Lever                | Carbon Steel                        |                                   |                     |  |   |
| 16  | Backup O'ring        | Viton                               |                                   |                     |  |   |
| *17 | Identification Plate | Stainless Steel                     |                                   |                     |  |   |

\* Not Shown

\*\* Material used as standard on Class 600

# WALWORTH FIRE SAFE FLOATING BALL VALVES CLASS 150 FULL PORT

## Design Features

- Design in accordance with API-6D & API 608
- CLASS 150 as per ASME B16.34
- Full Port
- Two-piece body
- Fire safe design as per API 607
- Cast Steel Construction
- Bolted Body
- Flanged ends as per ASME B16.5
- End to end dimensions as per ASME B16.10
- Butt Weld ends as per ASME B16.25
- Gear Operator 6" and larger (Optional)

| Lever Operator     |                         |
|--------------------|-------------------------|
| Catalog Figure No. | Type of Ends            |
| 7112-Z             | Flanged Raised Face     |
| 7113-Z             | Flanged Ring Type Joint |
| 7114-Z             | Butt Weld               |

| Gear Operator      |                         |
|--------------------|-------------------------|
| Catalog Figure No. | Type of Ends            |
| 7122-Z             | Flanged Raised Face     |
| 7123-Z             | Flanged Ring Type Joint |
| 7124-Z             | Butt Weld               |

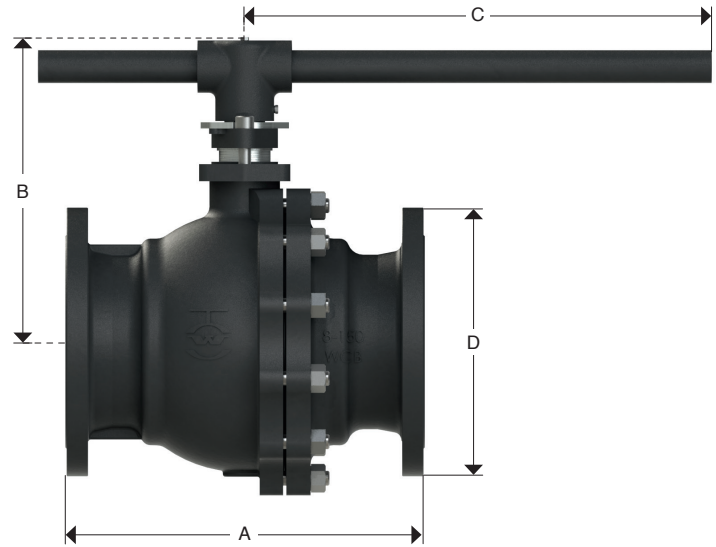

## Dimensions and Weights

| D<br>Nominal<br>Diameter | mm | 15    | 20    | 25    | 32    | 40    | 50    | 65     | 80     | 100    | 150    | 200    |
|--------------------------|----|-------|-------|-------|-------|-------|-------|--------|--------|--------|--------|--------|
|                          | in | 1/2   | 3/4   | 1     | 1 1/4 | 1 1/2 | 2     | 2 1/2  | 3      | 4      | 6      | 8      |
| A<br>(RF)                | mm | 108   | 117   | 127   | 140   | 165   | 178   | 191    | 203    | 229    | 394    | 457    |
|                          | in | 4 1/4 | 4 3/5 | 5     | 5 1/2 | 6 1/2 | 7     | 7 1/2  | 8      | 9      | 15 1/2 | 18     |
| D                        | mm | 89    | 98.5  | 108   | 117   | 127   | 152   | 178    | 190    | 229    | 279    | 343    |
|                          | in | 3 1/2 | 3 7/8 | 4 1/4 | 4 3/5 | 5     | 6     | 7      | 7 1/2  | 9      | 11     | 13 1/2 |
| B                        | mm | 72    | 92    | 105   | 91    | 125   | 135   | 153    | 172    | 210    | 303    | 352    |
|                          | in | 2 5/6 | 3 5/8 | 4 1/7 | 3 4/7 | 5     | 5 1/3 | 6      | 6 7/9  | 8 1/4  | 12     | 13 6/7 |
| C                        | mm | 160   | 160   | 160   | 160   | 180   | 230   | 400    | 400    | 400    | 800    | 800    |
|                          | in | 6 2/7 | 6 2/7 | 6 2/7 | 6 2/7 | 7     | 9     | 15 3/4 | 15 3/4 | 15 3/4 | 31 1/2 | 31 1/2 |
| Weight<br>7112-Z         | kg | 3     | 4     | 5     | 5     | 8     | 12    | 18     | 24     | 38     | 82     | 145    |
|                          | lb | 6.62  | 8.82  | 11.03 | 11.03 | 17.64 | 26.46 | 39.69  | 52.92  | 83.79  | 180.82 | 319.74 |

# WALWORTH FIRE SAFE FLOATING BALL VALVES CLASS 300 FULL PORT

## Design Features

- Design in accordance with API-6D & API 608
- CLASS 300 as per ASME B16.34
- Full Port
- Two-piece body
- Fire safe design as per API 607
- Cast Steel Construction
- Bolted Body
- Flanged ends as per ASME B16.5
- End to end dimensions as per ASME B16.10
- Butt Weld ends as per ASME B16.25
- Gear Operator 6" and larger (Optional)

| Lever Operator     |                         |
|--------------------|-------------------------|
| Catalog Figure No. | Type of Ends            |
| 7312-Z             | Flanged Raised Face     |
| 7313-Z             | Flanged Ring Type Joint |
| 7314-Z             | Butt Weld               |

| Gear Operator      |                         |
|--------------------|-------------------------|
| Catalog Figure No. | Type of Ends            |
| 7322-Z             | Flanged Raised Face     |
| 7323-Z             | Flanged Ring Type Joint |
| 7324-Z             | Butt Weld               |

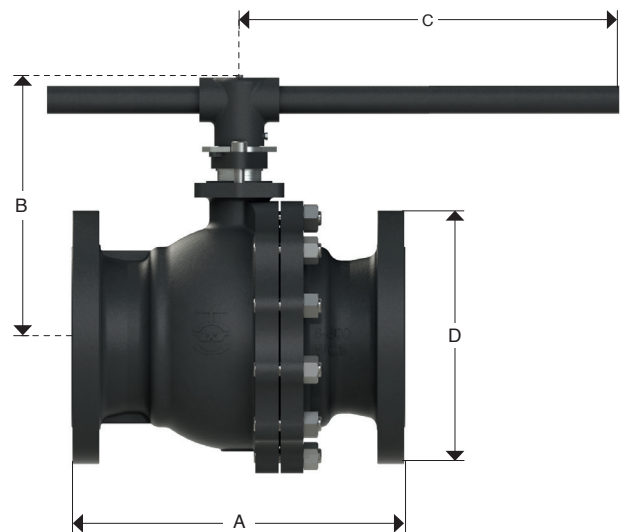

## Dimensions and Weights

| D<br>Nominal<br>Diameter | mm | 15    | 20    | 25    | 40    | 50    | 65     | 80     | 100    | 150    | 200    |
|--------------------------|----|-------|-------|-------|-------|-------|--------|--------|--------|--------|--------|
|                          | in | 1/2   | 3/4   | 1     | 1 1/2 | 2     | 2 1/2  | 3      | 4      | 6      | 8      |
| A<br>(RF)                | mm | 140   | 152   | 165   | 191   | 216   | 241    | 283    | 305    | 403    | 502    |
|                          | in | 5 1/2 | 6     | 6 1/2 | 7 1/2 | 8 1/2 | 9 1/2  | 11 1/7 | 12     | 15 6/7 | 19 3/4 |
| D                        | mm | 95    | 117   | 124   | 156   | 165   | 190    | 210    | 254    | 318    | 381    |
|                          | in | 3 3/4 | 4 3/5 | 4 7/8 | 6 1/7 | 6 1/2 | 7 1/2  | 8 1/4  | 10     | 12 1/2 | 15     |
| B                        | mm | 72    | 92    | 105   | 125   | 135   | 153    | 172    | 210    | 303    | 357    |
|                          | in | 2 5/6 | 3 5/8 | 4 1/7 | 5     | 5 1/3 | 6      | 6 7/9  | 8 1/4  | 12     | 14     |
| C                        | mm | 160   | 160   | 160   | 180   | 230   | 400    | 400    | 400    | 800    | 1000   |
|                          | in | 6 2/7 | 6 2/7 | 6 2/7 | 7     | 9     | 15 3/4 | 15 3/4 | 15 3/4 | 31 1/2 | 39 3/8 |
| Weight<br>7312-Z         | kg | 3     | 5     | 6     | 11    | 16    | 24     | 34     | 56     | 125    | 222    |
|                          | lb | 6.62  | 11.03 | 13.23 | 24.26 | 35.28 | 52.92  | 74.97  | 123.48 | 275.63 | 489.53 |

Note: Dimensions not regulated per norm, only for illustrative purposes, they can change without previous notice.

# WALWORTH FIRE SAFE FLOATING BALL VALVES CLASS 600 FULL PORT

## Design Features

- Design in accordance with API-6D & API 608
- CLASS 600 as per ASME B16.34
- Full Port
- Two-piece body
- Fire safe design as per API 607
- Cast Steel Construction
- Bolted Body
- Flanged ends as per ASME B16.5
- End to end dimensions as per ASME B16.10
- Butt Weld ends as per ASME B16.25
- Gear Operator 4" and larger (Optional)
- Valves could be supplied with ISO-5211 flange for operator installation (optional)

| Lever Operator     |                         |
|--------------------|-------------------------|
| Catalog Figure No. | Type of Ends            |
| 7612-Z             | Flanged Raised Face     |
| 7613-Z             | Flanged Ring Type Joint |
| 7614-Z             | Butt Weld               |

| Gear Operator      |                         |
|--------------------|-------------------------|
| Catalog Figure No. | Type of Ends            |
| 7622-Z             | Flanged Raised Face     |
| 7623-Z             | Flanged Ring Type Joint |
| 7624-Z             | Butt Weld               |

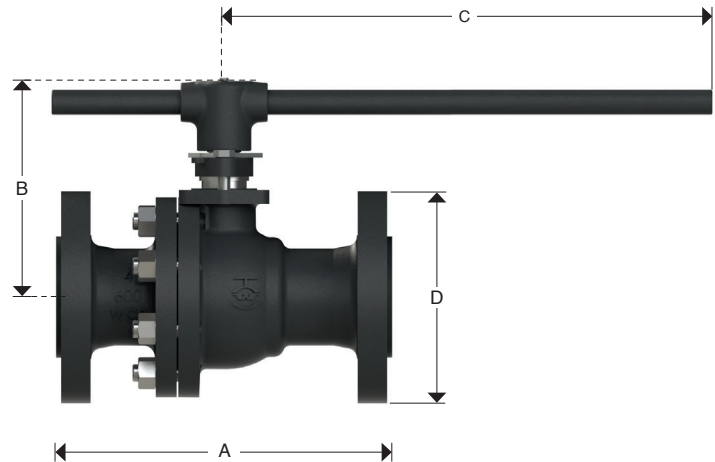

## Dimensions and Weights

| D<br>Nominal<br>Diameter | mm | 15    | 20    | 25    | 40    | 50     | 65     | 80     | 100    |
|--------------------------|----|-------|-------|-------|-------|--------|--------|--------|--------|
|                          | in | 1/2   | 3/4   | 1     | 1 1/2 | 2      | 2 1/2  | 3      | 4      |
| A<br>(RF)                | mm | 165   | 190   | 216   | 241   | 292    | 330    | 356    | 432    |
|                          | in | 6 1/2 | 7 1/2 | 8 1/2 | 9 1/2 | 11 1/2 | 13     | 14     | 17     |
| D                        | mm | 95    | 117   | 124   | 156   | 165    | 190    | 210    | 273    |
|                          | in | 3 3/4 | 4 3/5 | 4 7/8 | 6 1/7 | 6 1/2  | 7 1/2  | 8 1/4  | 10 3/4 |
| B                        | mm | 72    | 95    | 110   | 130   | 142    | 180    | 200    | 245    |
|                          | in | 2 5/6 | 3 3/4 | 4 1/3 | 5 1/8 | 5 3/5  | 7      | 7 7/8  | 9 2/3  |
| C                        | mm | 160   | 160   | 160   | 230   | 400    | 400    | 500    | 800    |
|                          | in | 6 2/7 | 6 2/7 | 6 2/7 | 9     | 15 3/4 | 15 3/4 | 19 2/3 | 31 1/2 |
| Weight<br>7612-Z         | kg | 5     | 7     | 9     | 17    | 25     | 42     | 56     | 85     |
|                          | lb | 11.03 | 15.44 | 19.85 | 37.49 | 55.13  | 92.61  | 123.48 | 187.43 |

Note: Dimensions not regulated per norm, only for illustrative purposes, they can change without previous notice.

# WALWORTH FIRE SAFE FLOATING BALL VALVES CLASS 150 REDUCED PORT

## Design Features

- Design in accordance with API-6D & API 608
- CLASS 150 as per ASME B16.34
- Reduced Port
- Two-piece body
- Fire safe design as per API 607
- Cast Steel Construction
- Bolted Body
- Flanged ends as per ASME B16.5
- End to end dimensions as per ASME B16.10
- Butt Weld ends as per ASME B16.25
- Gear Operator 6" X 4" and larger (Optional)

| Lever Operator     |                         |
|--------------------|-------------------------|
| Catalog Figure No. | Type of Ends            |
| 7112-RZ            | Flanged Raised Face     |
| 7113-RZ            | Flanged Ring Type Joint |
| 7114-RZ            | Butt Weld               |

| Gear Operator      |                         |
|--------------------|-------------------------|
| Catalog Figure No. | Type of Ends            |
| 7122-RZ            | Flanged Raised Face     |
| 7123-RZ            | Flanged Ring Type Joint |
| 7124-RZ            | Butt Weld               |

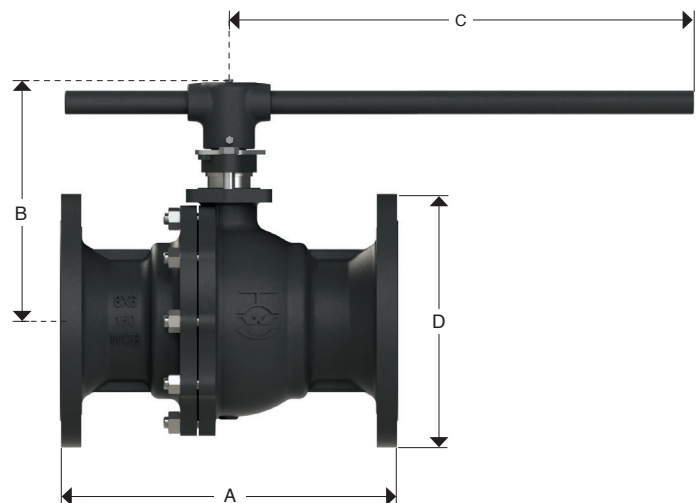

## Dimensions and Weights

| D<br>Nominal<br>Diameter | mm | 15 X 10   | 20 X 15   | 25 X 20 | 50 X 40   | 80 X 50 | 100 X 80 | 150 X 100 | 200 X 150 |
|--------------------------|----|-----------|-----------|---------|-----------|---------|----------|-----------|-----------|
|                          | in | 1/2 X 3/8 | 3/4 X 1/2 | 1 X 3/4 | 2 X 1 1/2 | 3 X 2   | 4 X 3    | 6 X 4     | 8 X 6     |
| A<br>(RF)                | mm | 108       | 117       | 127     | 178       | 203     | 229      | 394       | 457       |
|                          | in | 4 1/4     | 4 3/5     | 5       | 7         | 8       | 9        | 15 1/2    | 18        |
| D                        | mm | 89        | 98.5      | 108     | 152       | 190     | 229      | 279       | 343       |
|                          | in | 3 1/2     | 3 7/8     | 4 1/4   | 6         | 7 1/2   | 9        | 11        | 13 1/2    |
| B                        | mm | 72        | 72        | 92      | 125       | 135     | 172      | 210       | 303       |
|                          | in | 2 5/6     | 2 5/6     | 3 5/8   | 5         | 5 1/3   | 6 7/9    | 8 1/4     | 12        |
| C                        | mm | 160       | 160       | 160     | 180       | 230     | 400      | 400       | 800       |
|                          | in | 6 2/7     | 6 2/7     | 6 2/7   | 7         | 9       | 15 3/4   | 15 3/4    | 31 1/2    |
| Weight<br>7112-RZ        | kg | 3         | 3.5       | 5       | 9         | 15      | 25       | 60        | 105       |
|                          | lb | 6.62      | 7.72      | 11.03   | 19.85     | 33.08   | 55.13    | 132.30    | 231.53    |

Note: Dimensions not regulated per norm, only for illustrative purposes, they can change without previous notice.

# WALWORTH FIRE SAFE FLOATING BALL VALVES CLASS 300 REDUCED PORT

## Design Features

- Design in accordance with API-6D & API 608
- CLASS 300 as per ASME B16.34
- Reduced Port
- Two-piece body
- Fire safe design as per API 607
- Cast Steel Construction
- Bolted Body
- Flanged ends as per ASME B16.5
- End to end dimensions as per ASME B16.10
- Butt Weld ends as per ASME B16.25
- Gear Operator 6" X 4" and larger (Optional)

| Lever Operator (Reduced Port) |                         |
|-------------------------------|-------------------------|
| Catalog Figure No.            | Type of Ends            |
| 7312-RZ                       | Flanged Raised Face     |
| 7313-RZ                       | Flanged Ring Type Joint |
| 7314-RZ                       | Butt Weld               |

| Gear Operator (Reduced Port) |                         |
|------------------------------|-------------------------|
| Catalog Figure No.           | Type of Ends            |
| 7322-RZ                      | Flanged Raised Face     |
| 7323-RZ                      | Flanged Ring Type Joint |
| 7324-RZ                      | Butt Weld               |

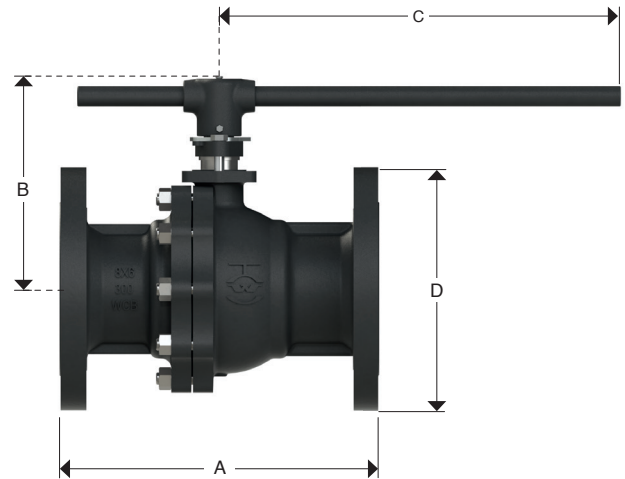

## Dimensions and Weights

| D<br>Nominal<br>Diameter | mm | 15 X 10   | 20 X 15   | 25 X 20 | 50 X 40   | 80 X 50 | 100 X 80 | 150 X 100 | 200 X 150 |
|--------------------------|----|-----------|-----------|---------|-----------|---------|----------|-----------|-----------|
|                          | in | 1/2 X 3/8 | 3/4 X 1/2 | 1 X 3/4 | 2 X 1 1/2 | 3 X 2   | 4 X 3    | 6 X 4     | 8 X 6     |
| A<br>(RF)                | mm | 108       | 117       | 127     | 178       | 203     | 229      | 394       | 457       |
|                          | in | 4 1/4     | 4 3/5     | 5       | 7         | 8       | 9        | 15 1/2    | 18        |
| D                        | mm | 89        | 98.5      | 108     | 152       | 190     | 229      | 279       | 343       |
|                          | in | 3 1/2     | 3 7/8     | 4 1/4   | 6         | 7 1/2   | 9        | 11        | 13 1/2    |
| B                        | mm | 72        | 72        | 92      | 125       | 135     | 172      | 210       | 303       |
|                          | in | 2 5/6     | 2 5/6     | 3 5/8   | 5         | 5 1/3   | 6 7/9    | 8 1/4     | 12        |
| C                        | mm | 160       | 160       | 160     | 180       | 230     | 400      | 400       | 800       |
|                          | in | 6 2/7     | 6 2/7     | 6 2/7   | 7         | 9       | 15 3/4   | 15 3/4    | 31 1/2    |
| Weight<br>7312-RZ        | kg | 4         | 5         | 6       | 14        | 25      | 48       | 90        | 130       |
|                          | lb | 8.82      | 11.03     | 13.23   | 30.87     | 55.13   | 105.84   | 198.46    | 286.66    |

Note: Dimensions not regulated per norm, only for illustrative purposes, they can change without previous notice.

# WALWORTH FIRE SAFE FLOATING BALL VALVES CLASS 600 REDUCED PORT

## Design Features

- Design in accordance with API-6D & API 608
- CLASS 600 as per ASME B16.34
- Reduced Port
- Two-piece body
- Fire safe design as per API 607
- Cast Steel Construction
- Bolted Body
- Flanged ends as per ASME B16.5
- End to end dimensions as per ASME B16.10
- Butt Weld ends as per ASME B16.25
- Gear Operator 4" X 3" and larger (Optional)

| Lever Operator (Reduced Port) |                         |
|-------------------------------|-------------------------|
| Catalog Figure No.            | Type of Ends            |
| 7612-RZ                       | Flanged Raised Face     |
| 7613-RZ                       | Flanged Ring Type Joint |
| 7614-RZ                       | Butt Weld               |

| Gear Operator (Reduced Port) |                         |
|------------------------------|-------------------------|
| Catalog Figure No.           | Type of Ends            |
| 7622-RZ                      | Flanged Raised Face     |
| 7623-RZ                      | Flanged Ring Type Joint |
| 7624-RZ                      | Butt Weld               |

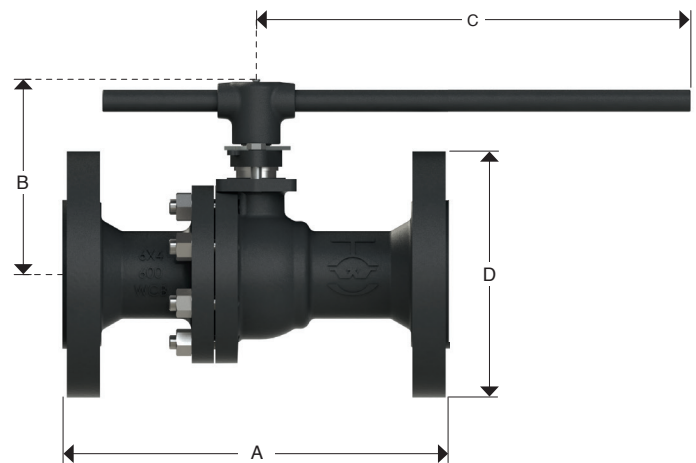

## Dimensions and Weights

| D<br>Nominal<br>Diameter | mm | 15 X 10   | 20 X 15   | 25 X 20 | 40 X 32       | 50 X 40   | 80 X 50 | 100 X 80 |
|--------------------------|----|-----------|-----------|---------|---------------|-----------|---------|----------|
|                          | in | 1/2 X 3/8 | 3/4 X 1/2 | 1 X 3/4 | 1 1/2 X 1 1/4 | 2 X 1 1/2 | 3 X 2   | 4 X 3    |
| A<br>(RF)                | mm | 165       | 190       | 216     | 241           | 292       | 356     | 432      |
|                          | in | 6 1/2     | 7 1/2     | 8 1/2   | 9 1/2         | 11 1/2    | 14      | 17       |
| D                        | mm | 95        | 117       | 124     | 156           | 165       | 210     | 273      |
|                          | in | 3 3/4     | 4 3/5     | 4 7/8   | 6 1/7         | 6 1/2     | 8 1/4   | 10 3/4   |
| B                        | mm | 72        | 72        | 95      | 113           | 130       | 142     | 200      |
|                          | in | 2 5/6     | 2 5/6     | 3 3/4   | 4 4/9         | 5 1/8     | 5 3/5   | 7 7/8    |
| C                        | mm | 160       | 160       | 160     | 200           | 230       | 400     | 500      |
|                          | in | 6 2/7     | 6 2/7     | 6 2/7   | 7 7/8         | 9         | 15 3/4  | 19 2/3   |
| Weight<br>7612-RZ        | kg | 5         | 6         | 7       | 13            | 21        | 39      | 72       |
|                          | lb | 11.03     | 13.23     | 15.44   | 28.67         | 46.31     | 86.00   | 158.77   |

Note: Dimensions not regulated per norm, only for illustrative purposes, they can change without previous notice.

# WALWORTH FIRE SAFE FLOATING BALL VALVES CLASS 1500

## Design Features

- Design in accordance with API 6D
- CLASS 1500 as per ASME B16.34
- Full Port
- Reduced Port (upon request)
- Three-pieces body
- Fire safe design as per API 607
- Forged Steel Construction
- Bolted Body
- Flanged ends as per ASME B16.5
- End to end dimensions as per ASME B16.10
- Butt Weld ends as per ASME B16.25

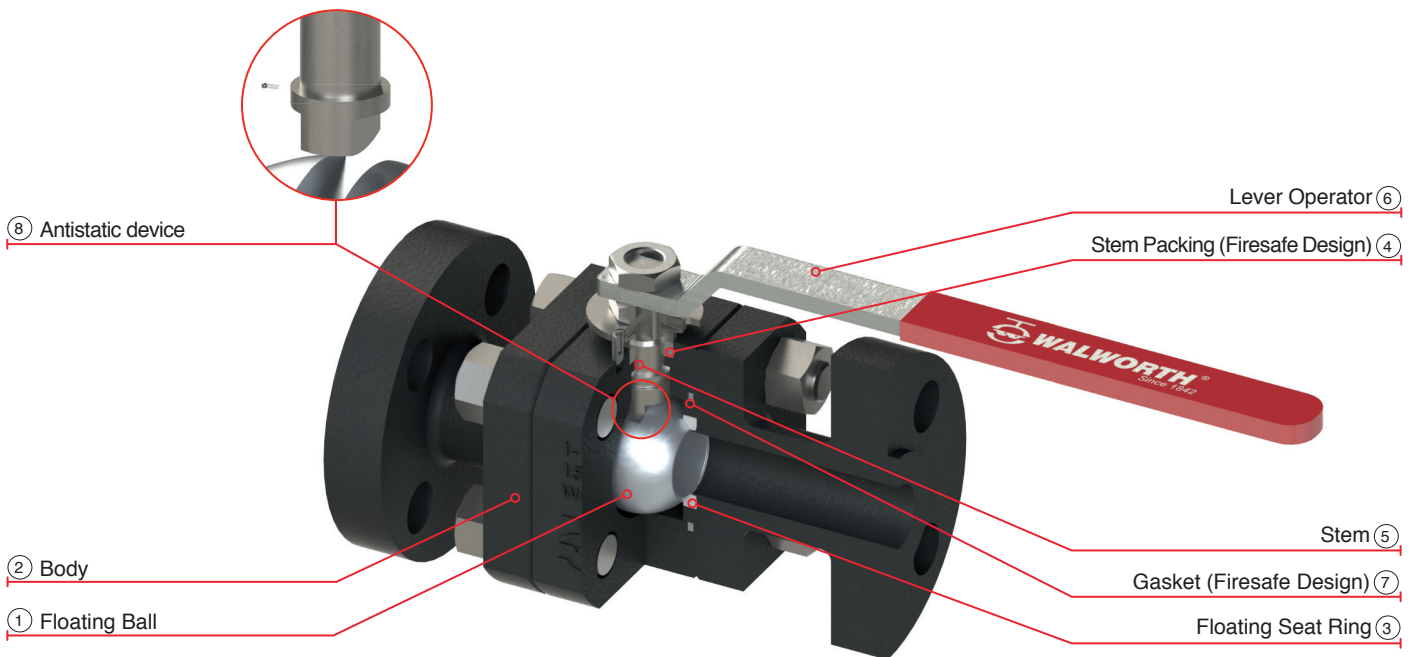

- ① Floating Ball. For all sizes & pressure ratings. The ball is only hold by the stem and is in movement with the direction of the fluid in order to seal with the seat rings.
- ② Body. Made of three pieces that includes the central body bolted with the end flanges.
- ③ Floating Seat Ring. Two independent dynamic soft seat rings that get in contact with the floating ball which seal in one side of the valve depending on the fluid direction.
- ④ Stem Packing (firesafe design). It is a graphite seal that ensure safety for fire emergency as it has a reliable operation with high levels of sealing integrity when operating the valve.
- ⑤ Stem. The stem design is anti blow out which is held up by the valve body and fits in the bottom with a small cavity in the top part of the floating ball.
- ⑥ Lever operator. It is supplied in all sizes to open and close the valve.
- ⑦ Gasket (firesafe design). It is a graphite seal that ensure safety for fire emergency as it has a reliable operation with high levels of sealing integrity between body and ends.
- ⑧ Antistatic device. An Inconel spring with a small ball is placed between stem-body to prevent static continuity.

# WALWORTH FIRE SAFE FLOATING BALL VALVES CLASS 1500

## Design Features

- Design in accordance with API 6D
- CLASS 1500 as per ASME B16.34
- Full Port
- Reduced Port (upon request)
- Three-pieces body
- Fire safe design as per API 607
- Forged Steel Construction
- Bolted Body
- Flanged ends as per ASME B16.5
- End to end dimensions as per ASME B16.10
- Butt Weld ends as per ASME B16.25

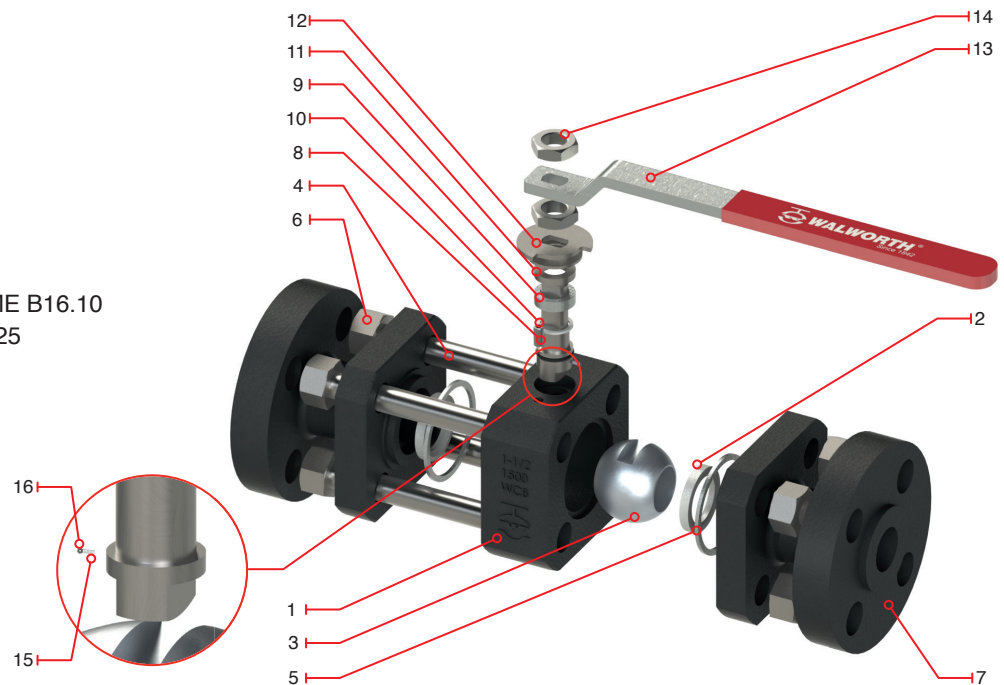

## Regular Bill of Materials

| No. | Description          | Carbon Steel with Trim F4 (SS304)   | Carbon Steel with Trim F3 (SS316) | Stainless Steel 316     | Carbon Steel with Trim F4 (SS304) NACE | Stainless Steel 316 with Trim F3 (SS316) NACE |  |
|-----|----------------------|-------------------------------------|-----------------------------------|-------------------------|--|---|--|
| 1   | Body                 | ASTM A105                           | ASTM A105                         | ASTM A182 Gr. F316      | ASTM A105                              | ASTM A182 Gr. F316                            |  |
| 2   | Seat Ring            | Nylon                               |                                   |                         |  |   |  |
| 3   | Ball                 | ASTM A182 Gr. F304                  | ASTM A182 Gr. F316                | ASTM A182 Gr. F316      | ASTM A182 Gr. F304                     | ASTM A182 Gr. F316                            |  |
| 4   | Stud                 | ASTM A193 Gr. B7                    | ASTM A193 Gr. B7                  | ASTM A193 Gr. B8        | ASTM A193 Gr. B7M                      | ASTM A193 Gr. B8M                             |  |
| 5   | Gasket               | Flexible Graphite + Stainless Steel |                                   |                         |  |   |  |
| 6   | Nut                  | ASTM A194 Gr. 2H                    | ASTM A194 Gr. 2H                  | ASTM A194 Gr. 8         | ASTM A194 Gr. 2HM                      | ASTM A194 Gr. 8M                              |  |
| 7   | End                  | ASTM A105                           | ASTM A105                         | ASTM A182 Gr. F316      | ASTM A105                              | ASTM A182 Gr. F316                            |  |
| 8   | Stem                 | ASTM A564 Gr 630 17-4PH             | ASTM A564 Gr 630 17-4PH           | ASTM A564 Gr 630 17-4PH | ASTM A564 Gr 630 17-4PH                | ASTM A564 Gr 630 17-4PH                       |  |
| 9   | Packing              | Flexible Graphite                   |                                   |                         |  |   |  |
| 10  | Stem Seat            | RPTFE                               |                                   |                         |  |   |  |
| 11  | Washer               | Carbon or Stainless Steel           |                                   |                         |  |   |  |
| 12  | Stop Plate           | Carbon or Stainless Steel           |                                   |                         |  |   |  |
| 13  | Lever                | Carbon Steel                        |                                   |                         |  |   |  |
| 14  | Stem Nut             | ASTM A194 Gr. 2H                    | ASTM A194 Gr. 2H                  | ASTM A194 Gr. 8         | ASTM A194 Gr. 2HM                      | ASTM A194 Gr. 8M                              |  |
| 15  | Antistatic Spring    | Inconel 750                         |                                   |                         |  |   |  |
| 16  | Small ball           | Stainless Steel                     |                                   |                         |  |   |  |
| *17 | Identification Plate | Stainless Steel                     |                                   |                         |  |   |  |

\* Not Shown

# WALWORTH FIRE SAFE FLOATING BALL VALVES CLASS 1500

## Design Features

- Design in accordance with API 6D
- CLASS 1500 as per ASME B16.34
- Full Port
- Three-pieces body
- Fire safe design as per API 607
- Forged Steel Construction
- Bolted Body
- Flanged ends as per ASME B16.5
- End to end dimensions as per ASME B16.10
- Butt Weld ends as per ASME B16.25

| Lever Operator     |                         |
|--------------------|-------------------------|
| Catalog Figure No. | Type of Ends            |
| 7512-Z             | Flanged Raised Face     |
| 7513-Z             | Flanged Ring Type Joint |
| 7514-Z             | Butt Weld               |

| Lever Operator (Reduced Port) |                         |
|-------------------------------|-------------------------|
| Catalog Figure No.            | Type of Ends            |
| 7512-RZ                       | Flanged Raised Face     |
| 7513-RZ                       | Flanged Ring Type Joint |
| 7514-RZ                       | Butt Weld               |

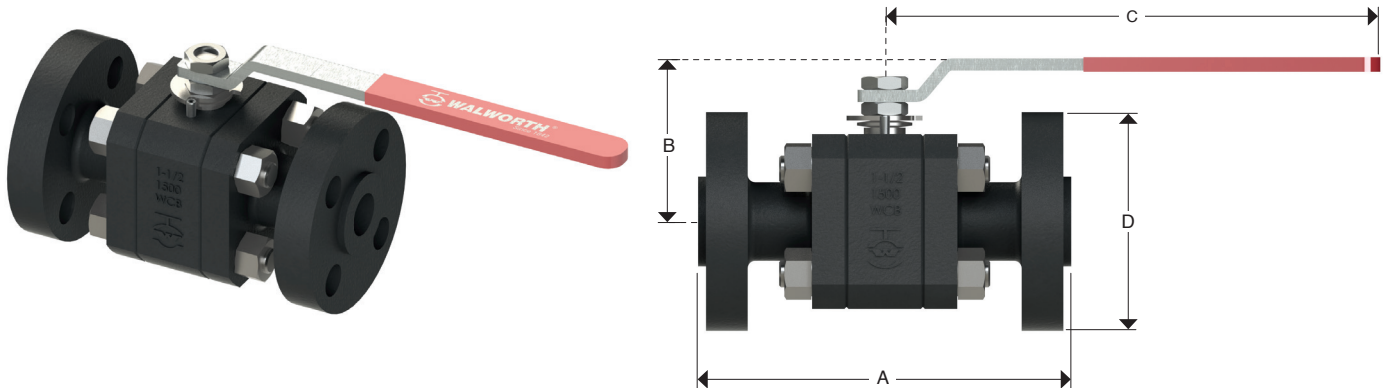

## Dimensions and Weights

| D<br>Nominal<br>Diameter | mm | 15    | 20    | 25    | 32    | 40     |
|--------------------------|----|-------|-------|-------|-------|--------|
|                          | in | 1/2   | 3/4   | 1     | 1 1/4 | 1 1/2  |
| A<br>(RF)                | mm | 216   | 229   | 254   | 279   | 305    |
|                          | in | 8 1/2 | 9     | 10    | 11    | 12     |
| D                        | mm | 121   | 130   | 149   | 159   | 178    |
|                          | in | 4 3/4 | 5 1/8 | 5 6/7 | 6 1/4 | 7      |
| B                        | mm | 75    | 81    | 105   | 125   | 150    |
|                          | in | 3     | 3 1/5 | 4 1/7 | 5     | 6      |
| C                        | mm | 180   | 230   | 230   | 230   | 400    |
|                          | in | 7     | 9     | 9     | 9     | 15 3/4 |
| Weight<br>7512-Z         | kg | 9     | 11    | 17    | 23    | 29     |
|                          | lb | 19.85 | 24.26 | 37.49 | 50.72 | 63.95  |

Note: Dimensions not regulated per norm, only for illustrative purposes, they can change without previous notice.

# WALWORTH FIRE SAFE FLOATING BALL VALVES

## CLASS 800, 1500 & 2500 (THREADED OR SOCKET WELD ENDS)

### Design Features

- Design in accordance with API 608 for class 800 or as per ASME 16.34 for classes 1500 & 2500
- CLASS 800 as per API 602, 1500 & 2500 as per ASME B16.34
- Full Port
- Reduced Port (upon request)
- Three-pieces body
- Fire safe design as per API 607
- Forged Steel Construction
- Bolted Body
- Threaded ends as per ASME B1.20.1
- End to end dimensions as per WALWORTH standard
- Socket Weld ends as per ASME B16.11
- Gear Operator (Optional)

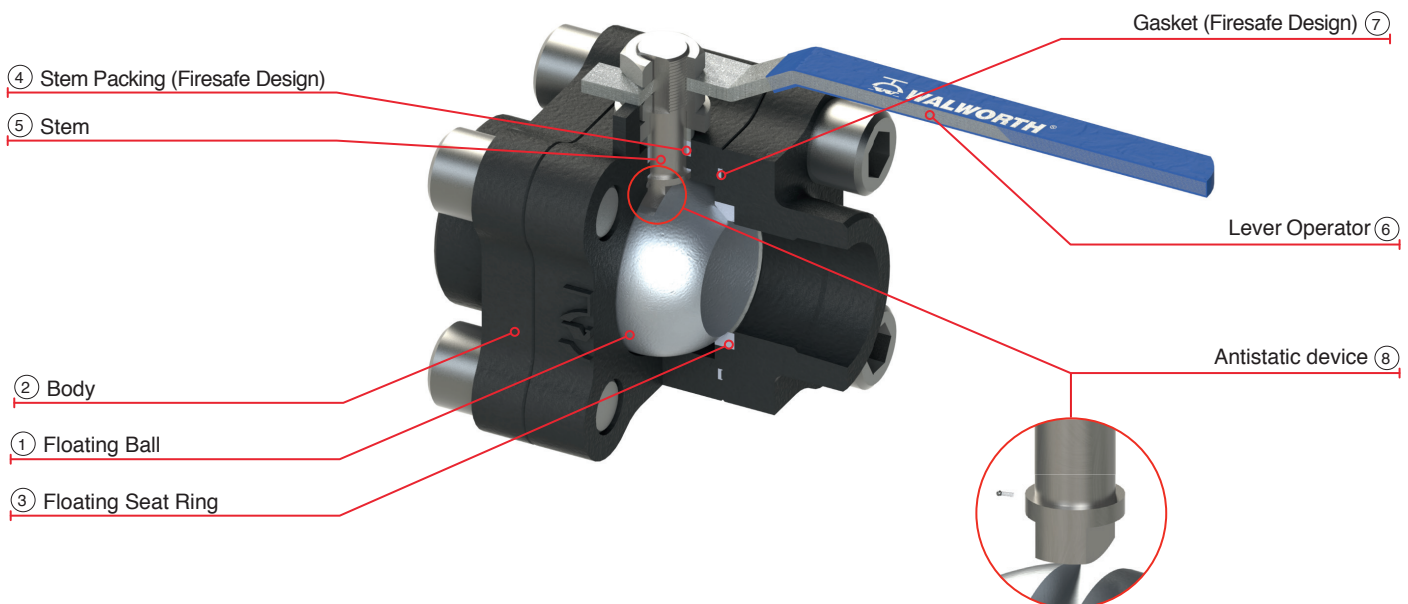

- ① Floating Ball. For all sizes & pressure ratings. The ball is only held by the stem and is in movement with the direction of the fluid in order to seal with the seat rings.
- ② Body. Made of three pieces that includes the central body bolted with the end flanges.
- ③ Floating Seat Ring. Two independent dynamic soft seat rings that get in contact with the floating ball which seal in one side of the valve depending on the fluid direction.
- ④ Stem Packing (firesafe design). It is a graphite seal that ensure safety for fire emergency as it has a reliable operation with high levels of sealing integrity when operating the valve.
- ⑤ Stem. The stem design is anti blow out and with an antistatic structure which is held up by the valve body and fits in the bottom in a small cavity in the top part of the floating ball.
- ⑥ Lever operator. It is supplied in all sizes to open and close the valve.
- ⑦ Gasket (firesafe design). It is a graphite seal that ensure safety for fire emergency as it has a reliable operation with high levels of sealing integrity between body and ends.
- ⑧ Antistatic device. An Inconel spring with a small ball is placed between stem-body to prevent static continuity.

# WALWORTH FIRE SAFE FLOATING BALL VALVES CLASS 800, 1500 & 2500 (THD OR SW ENDS)

## Design Features

- Design in accordance with API 608 for class 800 or as per ASME 16.34 for classes 1500 & 2500
- CLASS 800 as per API 602, 1500 & 2500 as per ASME B16.34
- Full Port
- Reduced Port (optional)
- Three-pieces body
- Fire safe design as per API 607
- Forged Steel Construction
- Bolted Body
- Threaded ends as per ASME B1.20.1
- End to end dimensions as per WALWORTH standard
- Socket Weld ends as per ASME B16.11
- Gear Operator (Optional)

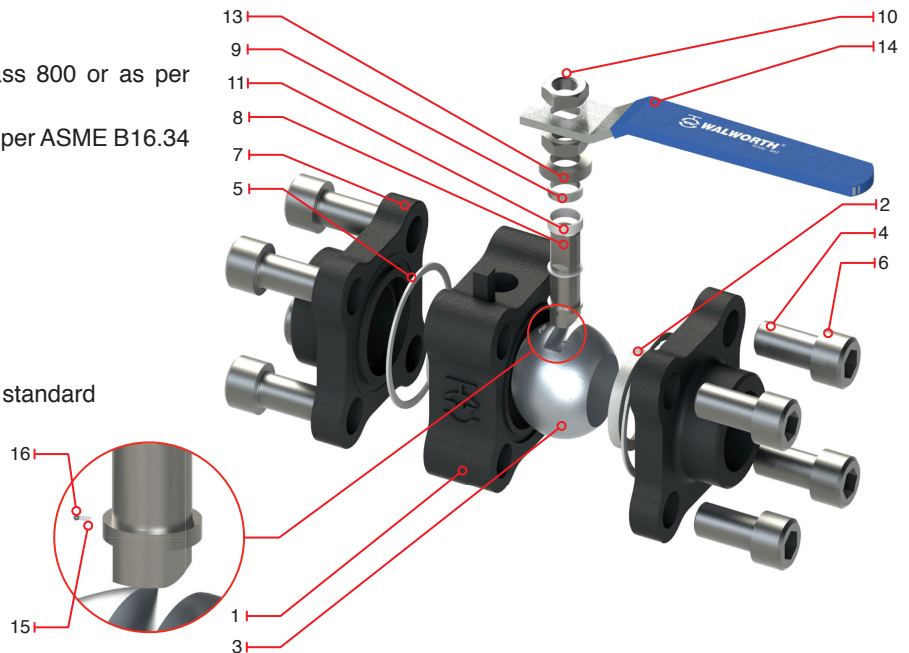

## Regular Bill of Materials

| No. | Description                       | Carbon Steel with Trim F4 (SS304) | Carbon Steel with Trim F3 (SS316) | Stainless Steel 316           | Carbon Steel with Trim F4 (SS304) NACE | Stainless Steel 316 with Trim F3 (SS316) NACE |
|-----|-----------------------------------|-----------------------------------|-----------------------------------|-------------------------------|--|---|
| 1   | Body                              | ASTM A105                         | ASTM A105                         | ASTM A182 Gr. F316            | ASTM A105                              | ASTM A182 Gr. F316                            |
| 2   | Seat Ring                         | Nylon                             |                                   |                               |  |   |
| 3   | Ball                              | ASTM A182 Gr. F304                | ASTM A182 Gr. F316                | ASTM A182 Gr. F316            | ASTM A182 Gr. F304                     | ASTM A182 Gr. F316                            |
| 4   | Stud                              | ASTM A193 Gr. B7                  | ASTM A193 Gr. B7                  | ASTM A193 Gr. B8              | ASTM A193 Gr. B7M                      | ASTM A193 Gr. B8M                             |
| 5   | Gasket                            | Graphite                          |                                   |                               |  |   |
| 6   | Nut                               | ASTM A194 Gr. 2H                  | ASTM A194 Gr. 2H                  | ASTM A194 Gr. 8               | ASTM A194 Gr. 2HM                      | ASTM A194 Gr. 8M                              |
| 7   | End                               | ASTM A105                         | ASTM A105                         | ASTM A182 Gr. F316            | ASTM A105                              | ASTM A182 Gr. F316                            |
| 8   | Stem                              | ASTM A182 GR F304 OR 17-4PH**     | ASTM A182 GR F316 OR 17-4PH**     | ASTM A182 GR F316 OR 17-4PH** | ASTM A182 GR F304 OR 17-4PH**          | ASTM A182 GR F316 OR 17-4PH**                 |
| 9   | Packing                           | Flexible Graphite                 |                                   |                               |  |   |
| 10  | Stem Nut                          | ASTM A194 Gr. 2H                  | ASTM A194 Gr. 2H                  | ASTM A193 Gr. 8               | ASTM A193 Gr. 2HM                      | ASTM A193 Gr. 8M                              |
| 11  | Stem Seat                         | RPTFE                             |                                   |                               |  |   |
| *12 | Stem O'ring (only for class 2500) | Viton                             |                                   |                               |  |   |
| 13  | Washer                            | Carbon or Stainless Steel         |                                   |                               |  |   |
| 14  | Lever                             | Carbon Steel                      |                                   |                               |  |   |
| 15  | Antistatic Spring                 | Inconel 750                       |                                   |                               |  |   |
| 16  | Small Ball                        | Stainless Steel                   |                                   |                               |  |   |
| *17 | Identification Plate              | Stainless Steel                   |                                   |                               |  |   |

\* Not Shown

\*\* Material used as standard on class 1500 & 2500

# WALWORTH FIRE SAFE FLOATING BALL VALVES CLASS 800 (THD OR SW ENDS)

- Design in accordance with API 608
- CLASS 800 as per API 602
- Full Port
- Three-pieces body
- Fire safe design as per API 607
- Forged Steel Construction
- Bolted Body
- Threaded ends as per ASME B1.20.1
- End to end dimensions as per WALWORTH standard
- Socket Weld ends as per ASME B16.11

| Lever Operator     |                              |
|--------------------|------------------------------|
| Catalog Figure No. | Type of Ends                 |
| 7811-Z             | Threaded (S)                 |
| 7817-Z             | Socket Weld (SW)             |
| 7810-Z             | Threaded X Socket Weld (SSW) |

| Lever Operator (Reduced Port) |                              |
|-------------------------------|------------------------------|
| Catalog Figure No.            | Type of Ends                 |
| 7811-RZ                       | Threaded (S)                 |
| 7817-RZ                       | Socket Weld (SW)             |
| 7810-RZ                       | Threaded X Socket Weld (SSW) |

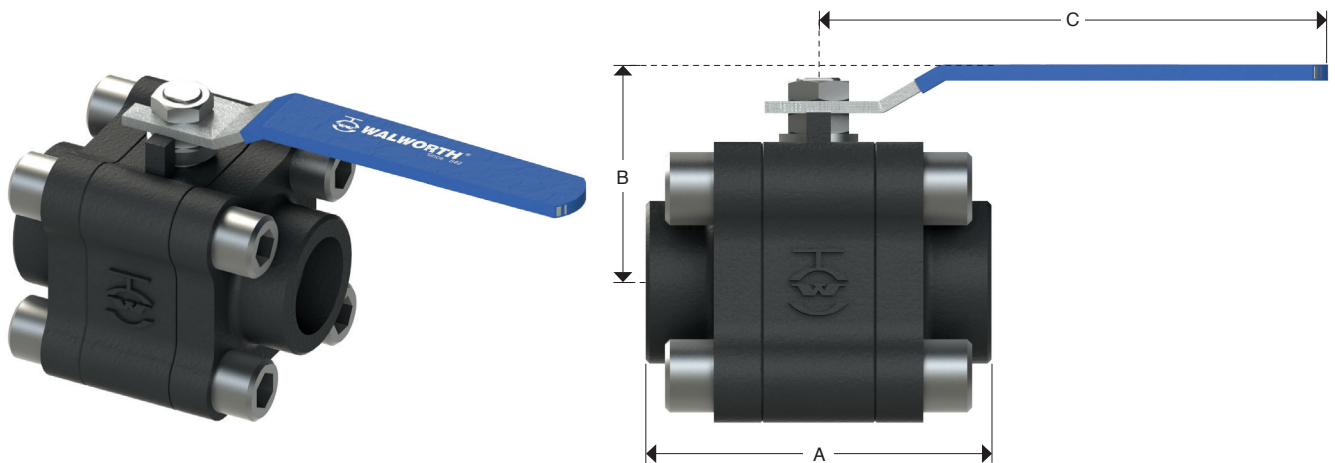

## Dimensions and Weights

| D<br>Nominal<br>Diameter | mm | 15    | 20    | 25    | 40    | 50    |
|--------------------------|----|-------|-------|-------|-------|-------|
|                          | in | 1/2   | 3/4   | 1     | 1 1/2 | 2     |
| A                        | mm | 92    | 108   | 120   | 145   | 170   |
|                          | in | 3 5/8 | 4 1/4 | 4 5/7 | 5 5/7 | 6 2/3 |
| B                        | mm | 59    | 68    | 73    | 90    | 97    |
|                          | in | 2 1/3 | 2 2/3 | 2 7/8 | 3 1/2 | 3 5/6 |
| C                        | mm | <120  | 160   | 160   | 215   | 250   |
|                          | in | 4 5/7 | 6 2/7 | 6 2/7 | 8 1/2 | 9 5/6 |
| Weight<br>7811-Z         | kg | 1     | 1.7   | 2.7   | 4.7   | 8.2   |
|                          | lb | 2.21  | 3.75  | 5.95  | 10.36 | 18.08 |

Note: Dimensions not regulated per norm, only for illustrative purposes, they can change without previous notice.

# WALWORTH FIRE SAFE FLOATING BALL VALVES

## CLASS 1500 (THREADED OR SOCKET WELD ENDS)

- Design in accordance with ASME 16.34
- CLASS 800 as per API 602
- Full Port
- Three-pieces body
- Fire safe design as per API 607
- Forged Steel Construction
- Bolted Body
- Threaded ends as per ASME B1.20.1
- End to end dimensions as per WALWORTH standard
- Socket Weld ends as per ASME B16.11

| Lever Operator     |                              |
|--------------------|------------------------------|
| Catalog Figure No. | Type of Ends                 |
| 7511-Z             | Threaded (S)                 |
| 7517-Z             | Socket Weld (SW)             |
| 7510-Z             | Threaded X Socket Weld (SSW) |

| Lever Operator (Reduced Port) |                              |
|-------------------------------|------------------------------|
| Catalog Figure No.            | Type of Ends                 |
| 7511-RZ                       | Threaded (S)                 |
| 7517-RZ                       | Socket Weld (SW)             |
| 7510-RZ                       | Threaded X Socket Weld (SSW) |

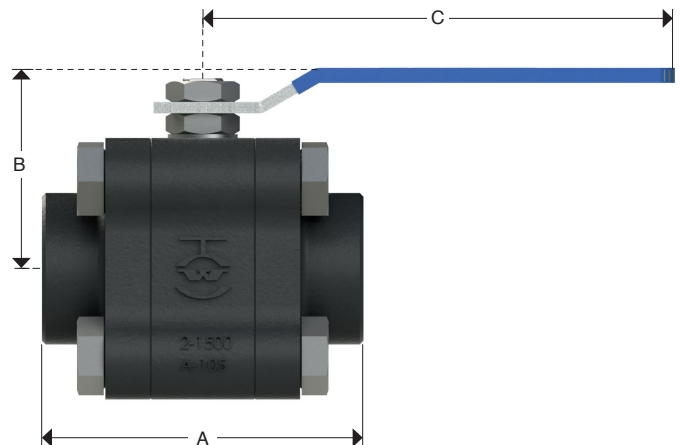

### Dimensions and Weights

| D<br>Nominal<br>Diameter | mm | 15    | 20    | 25    | 40    | 50    |
|--------------------------|----|-------|-------|-------|-------|-------|
|                          | in | 1/2   | 3/4   | 1     | 1 1/2 | 2     |
| A                        | mm | 92    | 108   | 120   | 145   | 170   |
|                          | in | 3 5/8 | 4 1/4 | 4 5/7 | 5 5/7 | 6 2/3 |
| B                        | mm | 59    | 68    | 73    | 90    | 97    |
|                          | in | 2 1/3 | 2 2/3 | 2 7/8 | 3 1/2 | 3 5/6 |
| C                        | mm | 120   | 160   | 160   | 215   | 250   |
|                          | in | 4 5/7 | 6 2/7 | 6 2/7 | 8 1/2 | 9 5/6 |
| Weight<br>7511-Z         | kg | 1.2   | 2     | 3.5   | 6     | 9.5   |
|                          | lb | 2.65  | 4.41  | 7.72  | 13.23 | 20.95 |

Note: Dimensions not regulated per norm, only for illustrative purposes, they can change without previous notice.

# WALWORTH FIRE SAFE FLOATING BALL VALVES

## CLASS 2500 (THREADED OR SOCKET WELD ENDS)

- Design in accordance with ASME 16.34
- CLASS 2500 as per ASME B16.34
- Full Port
- Three-pieces body
- Fire safe design as per API 607
- Forged Steel Construction
- Bolted Body
- Threaded ends as per ASME B1.20.1
- End to end dimensions as per WALWORTH standard
- Socket Weld ends as per ASME B16.11

| Lever Operator     |                              |
|--------------------|------------------------------|
| Catalog Figure No. | Type of Ends                 |
| 7211-Z             | Threaded (S)                 |
| 7217-Z             | Socket Weld (SW)             |
| 7210-Z             | Threaded X Socket Weld (SSW) |

| Lever Operator (Reduced Port) |                              |
|-------------------------------|------------------------------|
| Catalog Figure No.            | Type of Ends                 |
| 7211-RZ                       | Threaded (S)                 |
| 7217-RZ                       | Socket Weld (SW)             |
| 7210-RZ                       | Threaded X Socket Weld (SSW) |

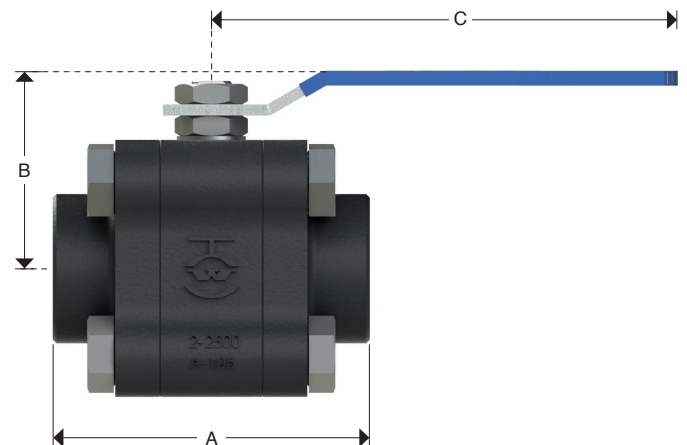

### Dimensions and Weights

| D<br>Nominal<br>Diameter | mm | 15    | 20    | 25    | 40     |
|--------------------------|----|-------|-------|-------|--------|
|                          | in | 1/2   | 3/4   | 1     | 1 1/2  |
| A                        | mm | 170   | 190   | 205   | 260    |
|                          | in | 6 2/3 | 7 1/2 | 8     | 10 1/4 |
| B                        | mm | 62    | 75    | 80    | 111    |
|                          | in | 2 4/9 | 3     | 3 1/7 | 4 3/8  |
| C                        | mm | 220   | 250   | 250   | 400    |
|                          | in | 8 2/3 | 9 5/6 | 9 5/6 | 15 3/4 |
| Weight<br>7211-Z         | kg | 2.8   | 4.5   | 7     | 15     |
|                          | lb | 6.17  | 9.92  | 15.44 | 33.08  |

Note: Dimensions not regulated per norm, only for illustrative purposes, they can change without previous notice.

## ACCESSORIES FOR OPERATION

### Locking Device

Valves are designed with locking devices as per request, just to put a lock in the lockholes to prevent misoperation in the fully opened or closed position of people not authorized to use them, specially when the valves are mounted outdoors or when the valves are not allowed to be opened or closed by technical process. This locking device is designed for standard lock usage, valves are not supplied with the lock.

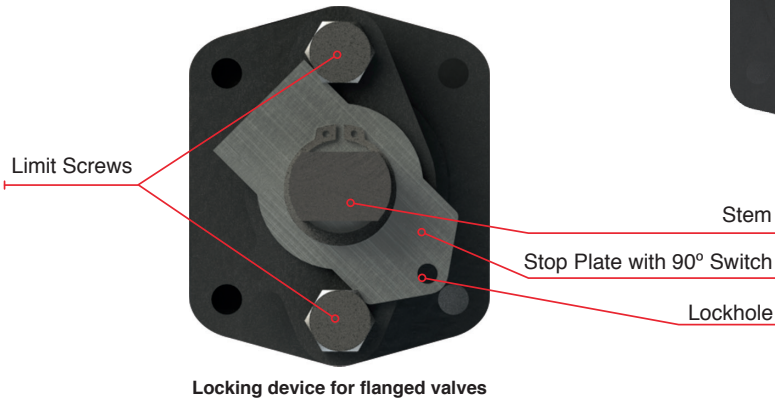

### Flange ISO 5211

This flange connection could be provided in the top of the valve to install an operator device by removing the lever.

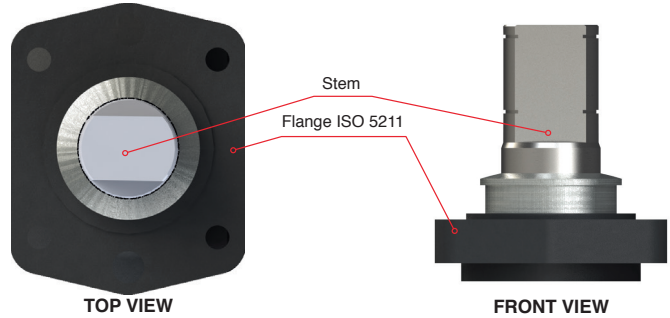

## PRESSURE-TEMPERATURE RATINGS

### PRESSURE-TEMPERATURE GRAPH FOR SOFT SEALS

The following graph shows the soft seals service performance curves at different temperatures and pressures as a reference.

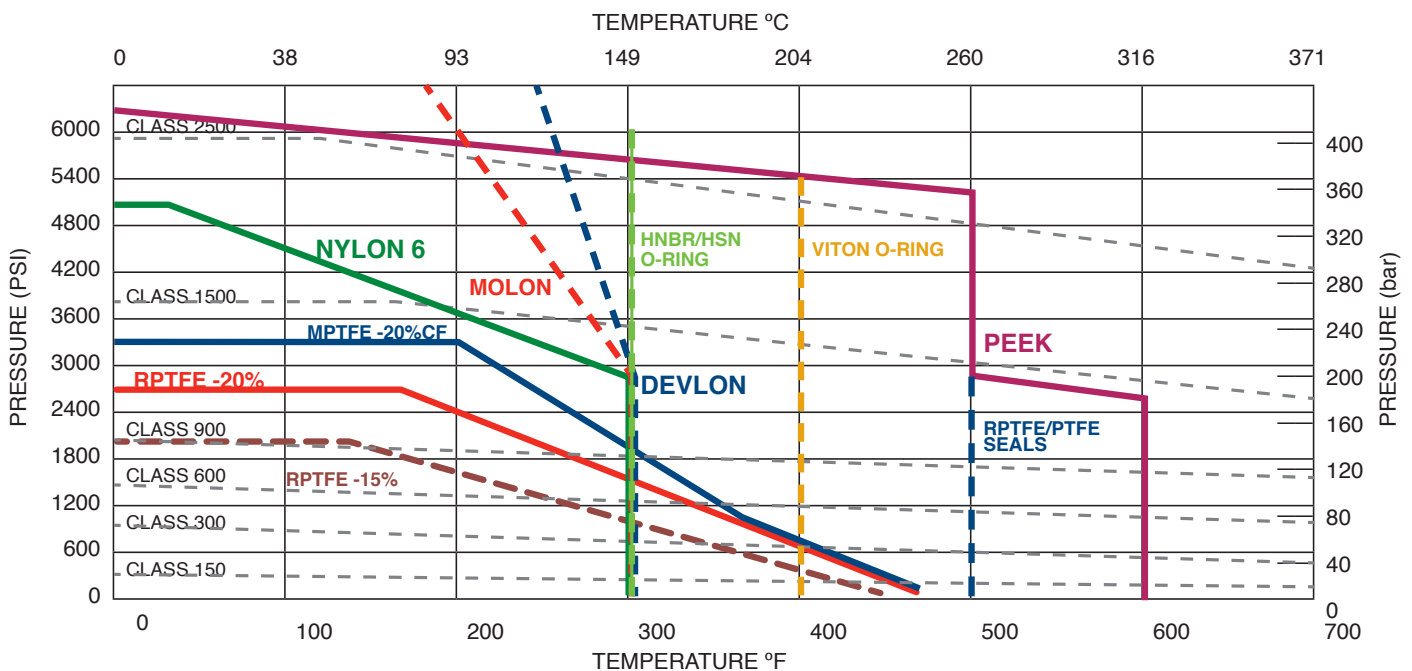

# PRESSURE-TEMPERATURE RATINGS

## SOFT SEAT INSERT MATERIALS (PRESSURE-TEMPERATURE)

| CLASS | TEMPERATURE °F (°C) |           |           |           |           |           |
|-------|---------------------|-----------|-----------|-----------|-----------|-----------|
|       | 100 (38)            | 200 (93)  | 300 (149) | 400 (204) | 500 (260) | 600 (316) |
| 150   | RPTFE-15%           | RPTFE-15% | RPTFE-15% | RPTFE-15% | RPTFE-15% | RPTFE-15% |
| 300   | RPTFE-15%           | RPTFE-15% | MOLON     | PEEK      | PEEK      | PEEK      |
| 600   | RPTFE-15%           | RPTFE-15% | MOLON     | PEEK      | PEEK      | PEEK      |
| 900   | NYLON 6             | NYLON 6   | MOLON     | PEEK      | PEEK      | PEEK      |
| 1500  | NYLON 6             | NYLON 6   | PEEK      | PEEK      | PEEK      | PEEK      |

■ "O"-Ring HNBR (AED) must be used as secondary seal

■ "O"-Ring VITON A&B FKM (AED) must be used as secondary seal

■ PEEK/RPTFE seals must be used as secondary seal

## FORGED CARBON STEEL ASTM A105<sup>(1)(2)</sup>, ASTM A182 Gr. LF2<sup>(1)</sup> & CAST STEEL A216 Gr. WCB<sup>(1)</sup>

| Temperature |           | Working class pressure |     |      |      |      |      |
|-------------|-----------|------------------------|-----|------|------|------|------|
| °F          | °C        | 150                    | 300 | 600  | 800  | 1500 | 2500 |
| - 20 to 100 | -29 to 38 | 285                    | 740 | 1480 | 1975 | 3705 | 6170 |
| 200         | 93        | 260                    | 680 | 1360 | 1810 | 3395 | 5655 |
| 300         | 149       | 230                    | 655 | 1310 | 1745 | 3270 | 5450 |
| 400         | 204       | 200                    | 635 | 1265 | 1690 | 3170 | 5280 |
| 500         | 260       | 170                    | 605 | 1205 | 1610 | 3015 | 5025 |
| 600         | 316       | 140                    | 570 | 1135 | 1515 | 2840 | 4730 |
| 650         | 343       | 125                    | 550 | 1100 | 1465 | 2745 | 4575 |
| 700         | 371       | 110                    | 530 | 1060 | 1415 | 2665 | 4425 |
| 750         | 399       | 98                     | 505 | 1015 | 1350 | 2535 | 4230 |
| 800         | 427       | 80                     | 410 | 825  | 1100 | 2055 | 3430 |
| 850         | 454       | 65                     | 320 | 640  | 850  | 1595 | 2655 |
| 900         | 482       | 50                     | 230 | 460  | 615  | 1150 | 1915 |
| 950         | 510       | 35                     | 135 | 275  | 365  | 685  | 1145 |
| 1000        | 538       | 20                     | 85  | 170  | 225  | 430  | 715  |

(1) Not recommended to temperatures above 800°F, the carbide phase of steel may be converted to graphite. Permissible but not recommended for prolonged use above 800°F.

(2) Only killed steel shall be used above 850°F.

## FORGED STAINLESS STEEL ASTM A182 Gr. F304<sup>(1)</sup> & ASTM A351 Gr. CF8<sup>(1)</sup>

| Temperature |           | Working class pressure |     |      |      |      |      |
|-------------|-----------|------------------------|-----|------|------|------|------|
| °F          | °C        | 150                    | 300 | 600  | 800  | 1500 | 2500 |
| - 20 to 100 | -29 to 38 | 275                    | 720 | 1440 | 1920 | 3600 | 6000 |
| 200         | 93        | 230                    | 600 | 1200 | 1600 | 3000 | 5000 |
| 300         | 149       | 205                    | 540 | 1075 | 1435 | 2690 | 4480 |
| 400         | 204       | 190                    | 495 | 995  | 1325 | 2485 | 4140 |
| 500         | 260       | 170                    | 465 | 9320 | 1240 | 2330 | 3880 |
| 600         | 316       | 140                    | 440 | 885  | 1180 | 2210 | 3680 |
| 650         | 343       | 125                    | 430 | 865  | 1150 | 2160 | 3600 |
| 700         | 371       | 110                    | 420 | 845  | 1125 | 2110 | 3520 |
| 750         | 399       | 95                     | 415 | 825  | 1100 | 2065 | 3440 |
| 800         | 427       | 80                     | 405 | 710  | 1080 | 2030 | 3380 |
| 850         | 454       | 65                     | 395 | 790  | 1055 | 1980 | 3300 |
| 900         | 482       | 50                     | 390 | 780  | 1035 | 1945 | 3240 |
| 950         | 510       | 35                     | 380 | 765  | 1020 | 1910 | 3180 |
| 1000        | 538       | 20                     | 355 | 710  | 945  | 1770 | 2950 |
| 1050        | 566       | 20(*)                  | 325 | 650  | 865  | 1630 | 2715 |
| 1100        | 593       | 20(*)                  | 255 | 515  | 685  | 1285 | 2145 |
| 1150        | 621       | 20(*)                  | 205 | 410  | 545  | 1030 | 1715 |
| 1200        | 649       | 20(*)                  | 165 | 330  | 440  | 825  | 1370 |
| 1250        | 677       | 20(*)                  | 135 | 265  | 355  | 970  | 1115 |
| 1300        | 704       | 20(*)                  | 115 | 225  | 300  | 565  | 945  |
| 1350        | 732       | 20(*)                  | 95  | 185  | 250  | 465  | 770  |
| 1400        | 760       | 20(*)                  | 75  | 150  | 200  | 380  | 630  |
| 1450        | 788       | 20(*)                  | 60  | 115  | 155  | 290  | 485  |
| 1500        | 816       | 15(*)                  | 40  | 85   | 110  | 205  | 345  |

(1) At temperatures over 1,000°F, use only when the carbon content is 0.04% or higher.

(\*) Flanged end valve ratings terminate at 1,000°F

# PRESSURE-TEMPERATURE RATINGS

## FORGED STAINLESS STEEL ASTM A182 Gr. F316<sup>(1)</sup> & ASTM A351 Gr. CF8M<sup>(1)</sup>

| Temperature |           | Working class pressure |     |      |      |      |      |
|-------------|-----------|------------------------|-----|------|------|------|------|
| °F          | °C        | 150                    | 300 | 600  | 800  | 1500 | 2500 |
| - 20 to 100 | -29 to 38 | 275                    | 720 | 1440 | 1920 | 3600 | 6000 |
| 200         | 93        | 235                    | 620 | 1240 | 1655 | 3095 | 5160 |
| 300         | 149       | 215                    | 560 | 1120 | 1495 | 2795 | 4660 |
| 400         | 204       | 195                    | 515 | 1025 | 1370 | 2570 | 4280 |
| 500         | 260       | 170                    | 480 | 955  | 1275 | 2390 | 3980 |
| 600         | 316       | 140                    | 450 | 900  | 1205 | 2255 | 3760 |
| 650         | 343       | 125                    | 440 | 885  | 1180 | 2210 | 3680 |
| 700         | 371       | 110                    | 435 | 870  | 1160 | 2170 | 3620 |
| 750         | 399       | 95                     | 425 | 855  | 1140 | 2135 | 3560 |
| 800         | 427       | 80                     | 420 | 745  | 1125 | 2110 | 3520 |
| 850         | 454       | 65                     | 420 | 735  | 1115 | 2090 | 3480 |
| 900         | 482       | 50                     | 415 | 730  | 1105 | 2075 | 3460 |
| 950         | 510       | 35                     | 385 | 775  | 1030 | 1930 | 3220 |
| 1000        | 538       | 20                     | 365 | 725  | 970  | 1820 | 3030 |
| 1050        | 566       | 20                     | 360 | 720  | 960  | 1800 | 3000 |
| 1100        | 593       | 20(*)                  | 305 | 610  | 815  | 1525 | 2545 |
| 1150        | 621       | 20(*)                  | 235 | 475  | 630  | 1185 | 1970 |
| 1200        | 649       | 20(*)                  | 185 | 370  | 495  | 925  | 1545 |
| 1250        | 677       | 20(*)                  | 145 | 295  | 390  | 735  | 1230 |
| 1300        | 704       | 20(*)                  | 115 | 235  | 310  | 585  | 970  |
| 1350        | 732       | 20(*)                  | 95  | 190  | 255  | 480  | 800  |
| 1400        | 760       | 20(*)                  | 75  | 150  | 200  | 380  | 630  |
| 1450        | 788       | 20(*)                  | 60  | 115  | 155  | 290  | 475  |
| 1500        | 816       | 15(*)                  | 40  | 85   | 110  | 205  | 345  |

(1) At temperatures over 1,000°F, use only when the carbon content is 0.04% or higher.

(\*) Flanged end valve ratings terminate at 1,000°F

## CAST LOW TEMPERATURE CARBON STEEL ASTM A350 Gr. LCC<sup>(1)</sup>

| Temperature |           | Working class pressure |     |       |       |       |       |
|-------------|-----------|------------------------|-----|-------|-------|-------|-------|
| °F          | °C        | 150                    | 300 | 600   | 800   | 1500  | 2500  |
| - 20 to 100 | -29 to 38 | 290                    | 750 | 1,500 | 2,000 | 3,750 | 6,250 |
| 200         | 93        | 260                    | 750 | 1,500 | 2,000 | 3,750 | 6,250 |
| 300         | 149       | 230                    | 730 | 1,455 | 1,940 | 3,640 | 6,070 |
| 400         | 204       | 200                    | 705 | 1,405 | 1,875 | 3,520 | 5,865 |
| 500         | 260       | 170                    | 665 | 1,330 | 1,775 | 3,325 | 5,540 |
| 600         | 316       | 140                    | 605 | 1,210 | 1,615 | 3,025 | 5,040 |
| 650         | 343       | 125                    | 590 | 1,175 | 1,570 | 2,940 | 4,905 |
| 700         | 371       | 110                    | 555 | 1,110 | 1,480 | 2,775 | 4,630 |
| 750         | 399       | 95                     | 505 | 1,015 | 1,350 | 2,535 | 4,230 |
| 800         | 427       | 80                     | 410 | 825   | 1,100 | 2,055 | 3,430 |
| 850         | 454       | 65                     | 320 | 640   | 850   | 1,595 | 2,655 |
| 900         | 482       | 50                     | 225 | 445   | 595   | 1,115 | 1,855 |
| 950         | 510       | 35                     | 135 | 275   | 365   | 685   | 1,145 |
| 1000        | 538       | 20                     | 85  | 170   | 225   | 430   | 715   |

(1) Not to be used over 650°F.

## WALWORTH BODY AND TRIM MATERIALS

WALWORTH offers as standard the floating ball valves trim and body arrangements mentioned below, which configuration is suitable for the recommended service described in each of the materials. Any other trim or body material could be supplied upon request.

| Body                                     | WALWORTH Trim | Components                      |                               | Recommended Service   |
|--|---------------|---------------------------------|-------------------------------|---|
|  |               | Ball                            | Stem                          |   |
| BRASS                                    | F1            | SS-304 or Brass Chromium plated | Brass                         | Light commercial and residential applications including water and gas services            |
| ASTM A216 GR. WCB OR ASTM A105           | F2            | Stainless Steel 410             | Stainless Steel 410 or 17-4PH | Non-corrosive applications or general services including water, oil, steam and gases      |
| ASTM A216 GR. WCB OR ASTM A105           | F3            | Stainless Steel 316             | Stainless Steel 316 or 17-4PH | Non-corrosive applications or general services including water, oil, steam and gases      |
| ASTM A216 GR. WCB OR ASTM A105           | F4            | Stainless Steel 304             | Stainless Steel 304 or 17-4PH | Non-corrosive applications or general services including water, oil, steam and gases      |
| ASTM A350 Gr. LCC OR ASTM A182 Gr. LF2   | F3            | Stainless Steel 316             | Stainless Steel 316 or 17-4PH | Low Temperature applications  |
| ASTM A351 Gr. CF8M OR ASTM A182 Gr. F316 | F3            | Stainless Steel 316             | Stainless Steel 316 or 17-4PH | Corrosive systems as it has superior resistance to corrosive at high and low temperatures |

## TORQUE AND CV FLOW RATES FOR FLOATING BALL VALVES

The torques and CV flow rates mentioned in the table below are for reference. The torque data already includes a safety factor of 30%, in case that is needed an actuator shall be added another 20% to 30% safety factor.

The torques are calculated only for RPTFE seat inserts.

| Torque and CV data of floating ball valves |        |      |               |    |     |      |        |      |               |    |     |      |        |     |               |    |     |      |
|--|--------|------|---------------|----|-----|------|--------|------|---------------|----|-----|------|--------|-----|---------------|----|-----|------|
| Size                                       | 150Lb  |      |               |    |     |      | 300Lb  |      |               |    |     |      | 600Lb  |     |               |    |     |      |
|  | Torque |      | Stem Diameter |    | ISO | CV   | Torque |      | Stem Diameter |    | ISO | CV   | Torque |     | Stem Diameter |    | ISO | CV   |
|  | lb.ft  | N.m  | in            | mm |     |      | lb.ft  | N.m  | in            | mm |     |      | lb.ft  | N.m | in            | mm |     |      |
| 1/2"                                       | 14.8   | 20   | 1/2           | 12 | F04 | 25   | 22.1   | 30   | 1/2           | 12 | F04 | 25   | 29.5   | 40  | 1/2           | 12 | F04 | 25   |
| 3/4"                                       | 18.4   | 25   | 1/2           | 12 | F04 | 50   | 25.8   | 35   | 1/2           | 12 | F04 | 50   | 33.2   | 45  | 1/2           | 12 | F04 | 50   |
| 1"   | 25.8   | 35   | 5/9           | 14 | F05 | 100  | 29.5   | 40   | 5/9           | 14 | F05 | 100  | 66.4   | 90  | 5/9           | 14 | F05 | 100  |
| 1 1/4"                                     | 36.9   | 50   | 5/9           | 14 | F05 |      | 44.3   | 60   | 5/9           | 14 | F05 |      | 88.5   | 120 | 5/9           | 14 | F05 |      |
| 1 1/2"                                     | 44.3   | 60   | 5/6           | 21 | F07 | 270  | 59.0   | 80   | 5/6           | 21 | F07 | 270  | 95.9   | 130 | 5/6           | 21 | F07 | 270  |
| 2"   | 51.6   | 70   | 5/6           | 21 | F07 | 490  | 81.1   | 110  | 5/6           | 21 | F07 | 490  | 140.1  | 190 | 1             | 26 | F07 | 490  |
| 2 1/2"                                     | 84.8   | 115  | 1             | 26 | F07 | 950  | 136.4  | 185  | 1             | 26 | F07 | 950  | 265.5  | 360 | 1             | 26 | F10 | 950  |
| 3"   | 110.6  | 150  | 1             | 26 | F07 | 1160 | 166.0  | 225  | 1             | 26 | F07 | 1160 | 339.3  | 460 | 1 1/9         | 28 | F10 | 1160 |
| 4"   | 180.7  | 245  | 1 1/4         | 32 | F10 | 2200 | 302.4  | 410  | 1 1/4         | 32 | F10 | 2200 | 567.9  | 770 | 1 4/7         | 40 | F12 | 2200 |
| 5"   | 350.3  | 475  | 1 1/4         | 32 | F12 | 3800 | 704.4  | 955  | 1 1/4         | 32 | F12 | 3800 |        |     |               |    |     |      |
| 6"   | 461.0  | 625  | 1 4/7         | 40 | F12 | 5100 | 1003.1 | 1360 | 1 4/7         | 40 | F12 | 5100 |        |     |               |    |     |      |
| 8"   | 1003.1 | 1360 | 1 8/9         | 48 | F12 | 9300 | 1696.4 | 2300 | 1 8/9         | 48 | F14 | 9300 |        |     |               |    |     |      |
| 10"  | 1622.6 | 2200 | 2 1/6         | 55 | F16 |      |        |      |               |    |     |      |        |     |               |    |     |      |

# WALWORTH FLOATING BALL VALVES FIGURES

| Model |                     | Class |           | Operation |  | Ends |                       |
|-------|---------------------|-------|-----------|-----------|--|------|-----------------------|
| 7     | Floating Ball Valve | 1     | 150 ANSI  | 1         | Lever                                  | 1    | Threaded (S)          |
|       |                     | 2     | 2500 ANSI | 2         | Gear Operator                          | 2    | Raised Face (RF)      |
|       |                     | 3     | 300 ANSI  | 3         | Actuator                               | 3    | Ring Type Joint (RTJ) |
|       |                     | 4     | 2000 WOG  | 5         | Bare Stem prepared to receive actuator | 4    | Butt Weld (WE)        |
|       |                     | 5     | 1500 ANSI |           |  | 7    | Socket Weld (SW)      |
|       |                     | 6     | 600 ANSI  | 0         | Threaded X Socket Weld (SSW)           |      |                       |
|       |                     | 7     | 600 WOG   |           |  |      |                       |
|       |                     | 8     | 800 API   |           |  |      |                       |
|       |                     | 9     | 900 ANSI  |           |  |      |                       |
|       |                     | 0     | 1000 WOG  |           |  |      |                       |

| Modifier Suffixes for Floating Ball Valves |                 |
|--|-----------------|
| R  | Reduced port    |
| Z  | Fire Safe valve |

### Examples:

|         |   |
|---------|---|
| 7312-RZ | "Fire safe floating ball valve, class 300, wrench operated, reduced port with raised face ends" |
| 7817-Z  | "Fire safe floating ball valve, class 800, wrench operated with socket weld ends"               |
| 7410    | "Floating ball valve class 2000 WOG, wrench operated with threaded by socket weld ends"         |

# HOW TO ORDER

WALWORTH Valves are identified by a figure number which describes main features. Identification procedure is intended to assist customers to specify the sort of valve required according to a specific need.



| Size   | WALWORTH Figure | Type of Port   | Design                 | Trim     | Base Material ASTM | Supplementary Requirements                       |
|--------|-----------------|----------------|------------------------|----------|--------------------|--|
| 3/8"   | 7010            | R= Reduced     | Z= Firesafe            | F1=Brass | Carbon Steel       | GO= Gear Operator                                |
| 1/4"   | 7011            | In Blank= Full | In Blank= Non Firesafe | F2=SS410 | A105               | MOV= Motor Operated Valve                        |
| 1/2"   | 7017            |                |                        | F3=SS316 | WCB                | POV= Pneumatic Operated Valve                    |
| 3/4"   | 7410            |                |                        | F4=SS304 | Low Carbon Steel   | LD= Locking Device                               |
| 1"     | 7411            |                |                        |          | LF2                | NACE MR0175                                      |
| 1 1/4" | 7417            |                |                        |          | LCC                | NACE MR0103                                      |
| 1 1/2" | 7112            |                |                        |          | Stainless Steel    | SP= Special Paint                                |
| 2"     | 7113            |                |                        |          | F316               | SG= Special Gasket                               |
| 2 1/2" | 7114            |                |                        |          | F304               | SPK= Special Packing                             |
| 3"     | 7122            |                |                        |          | CF8                | VOC= Certification of Volatile organic compounds |
| 4"     | 7123            |                |                        |          | CF8M               | XX= Additional requirements                      |
| 6"     | 7124            |                |                        |          |                    |  |
| 8"     | 7312            |                |                        |          |                    |  |
| 10"    | 7313            |                |                        |          |                    |  |
| 12"    | 7314            |                |                        |          |                    |  |
|        | 7322            |                |                        |          |                    |  |
|        | 7323            |                |                        |          |                    |  |
|        | 7324            |                |                        |          |                    |  |
|        | 7612            |                |                        |          |                    |  |
|        | 7613            |                |                        |          |                    |  |
|        | 7614            |                |                        |          |                    |  |
|        | 7622            |                |                        |          |                    |  |
|        | 7623            |                |                        |          |                    |  |
|        | 7624            |                |                        |          |                    |  |
|        | 7512            |                |                        |          |                    |  |
|        | 7513            |                |                        |          |                    |  |
|        | 7514            |                |                        |          |                    |  |
|        | 7810            |                |                        |          |                    |  |
|        | 7811            |                |                        |          |                    |  |
|        | 7817            |                |                        |          |                    |  |
|        | 7510            |                |                        |          |                    |  |
|        | 7511            |                |                        |          |                    |  |
|        | 7517            |                |                        |          |                    |  |
|        | 7210            |                |                        |          |                    |  |
|        | 7211            |                |                        |          |                    |  |
|        | 7217            |                |                        |          |                    |  |
|        | 7711            |                |                        |          |                    |  |

### Examples:

|                                |   |
|--------------------------------|---|
| 3/4"-7011-F4-A105              | 3/4" Floating ball 1000 WOG Threaded ends Full Port Non Firesafe Design Trim F4 (SS304) Body A105                     |
| 2"-7312-RZ-F3-CF8M-NACE MR0175 | 2" Floating ball class 300 Raised Face ends Reduced Port Firesafe Design Trim F3 (SS316) Body CF8M as per NACE MR0175 |

# DESIGN BASIS

All of WALWORTH's Valve Designs, when applicable, follow one or more of the following standards:

|                       |   |
|-----------------------|---|
| <b>API</b>            | American Petroleum Institute:<br>API 598      Valve Inspection and Testing<br>API 6D      Pipeline Valves (Gate, Ball and Check)<br>API 602      Pressure rating for class 800<br>API 607      Fire Test for 1/4 Turn Soft-Seated Valves<br>API 608      Metal Ball Valves-Flanged, Threaded and Welding ends   |
| <b>ANSI Standards</b> | National Standards Institute:<br><b>ANSI B1.20.1</b> NPT General Purpose Pipe Threads (Inches)<br><b>ANSI B16.5</b> Pipeline Flanges and Flanged Fittings<br><b>ANSI B16.10</b> Face to Face and End to End Valve Dimensions<br><b>ANSI B16.11</b> Socket Weld General Purpose Dimensions<br><b>ANSI B16.25</b> Butt Weld Ends  |
| <b>MSS Standards</b>  | Manufacturer's Standardization Society<br><b>MSS SP-25</b> Standard Marking System for Valves, Fittings, Flanges and Unions<br><b>MSS SP-55</b> Quality Standard for Steel Castings for Valves, Flanges, Fittings and Other Piping Components/Visual Method for Evaluation of Surface Irregularities<br><b>MSS SP-72</b> Ball Valves with Flanged or Butt-Welding Ends for General Service<br><b>MSS SP-110</b> Ball Valves Threaded, Socket-Welding, Solder Joint, Grooved and Flared Ends   |
| <b>ASTM Standards</b> | American Society for Testing and Materials:<br><b>ASTM A-105</b> Standard Specification for Carbon Steel Forgings for Piping Applications<br><b>ASTM A-182</b> Standard Specification for Forged or Rolled Alloy Steel Pipe Flanges, Forged Fittings and Valves and Parts for High Temperature Service<br><b>ASTM A-193</b> Standard Specification for Alloy Steel and Stainless Steel Bolting Materials for High Temperature Service<br><b>ASTM A-194</b> Standard Specification for Carbon and Alloy Steel Nuts for High Pressure and High Temperature Service<br><b>ASTM A-216</b> Standard Specification for Carbon Steel Castings, Suitable for Fusion Welding and High Temperature Service<br><b>ASTM A-276</b> Standard Specification for Stainless and Heat-Resisting Steel Bars and Shapes<br><b>ASTM A-320</b> Standard Specification for Alloy Steel Bolting Materials for Low Temperature Service<br><b>ASTM A-350</b> Standard Specification for Carbon and Low Alloy Steel Forgings, Requiring Notch Toughness Testing for Piping Components<br><b>ASTM A-351</b> Standard Specification for Steel Austenitic and Austenitic-Ferritic (Duplex) Castings for Pressure Containing Parts<br><b>ASTM A-352</b> Standard Specification for Steel, Ferritic and Martensitic Castings for Pressure Containing Parts, Suitable for Low Temperature Service<br><b>ASTM A-515</b> Standard Specification for Carbon Steel Pressure Vessel Plates for Intermediate and High Temperature Service<br><b>ASTM A-564</b> Standard Specification for Hot-Rolled and Cold-Finished Age-Hardening Stainless Steel Bars and Shapes<br><b>ASTM B-124</b> Standard Specification for Copper and Copper Alloy Forging Rod, Bar, and Shapes<br><b>ASTM B-283</b> Standard Specification for Copper and Copper-Alloy Die Forgings (Hot-Pressed) |
| <b>NACE Standard</b>  | National Association of Corrosion Engineers<br><b>NACE MR0175</b> Sulfide Stress Corrosion Cracking Resistant Metallic Materials for Oil Field Equipment  |

# DESIGN BASIS

|   |  |
|---|--|
| <b>ASME Code</b>                        | American Society of Mechanical Engineers   |
| <b>ANSI/ASME B16.34</b>                 | Valves— Flanged, Threaded, and Welding End (Pressure-temperature ratings)                  |
| <b>ANSI/ASME B31.1</b>                  | Power Piping   |
| <b>ANSI/ASME B31.2</b>                  | Fuel Gas Piping  |
| <b>ASME/ANSI B31.3</b>                  | Process Piping   |
| <b>BS Code</b>                          | British Standard Institution   |
| <b>BS 5351</b>                          | Specification for steel ball valves for the petroleum, petrochemical and allied industries |
| <b>Boiler and Pressure Vessel Code:</b> |  |
| <b>Section II</b>                       | Part A - Ferrous Material Specifications   |
| <b>Section II</b>                       | Part B - Non - Ferrous Material Specifications   |
| <b>Section II</b>                       | Part C - Specifications for Welding Rods, Electrodes and Filler Metals                     |
| <b>Section V</b>                        | Non - Destructive Examination  |
| <b>Section VIII</b>                     | Rules for Construction of Pressure Vessels, Divisions 1 and 2                              |
| <b>Section IX</b>                       | Welding and Brazing Qualifications of Surface Irregularities                               |



# THE WALWORTH COMPANY GENERAL TERMS AND CONDITIONS

**ACCEPTANCE:** All quotations are for acceptance within 30 days from date of quotation unless extended in writing. In the event a purchase order is placed after this period of time. The WALWORTH Company reserves the right to quote base prices of all valves offered. All orders and contracts are subject to credit approval and acceptance by the WALWORTH Company.

**FREIGHT:** When prices are FOB point of shipment –no freight allowance, we will attempt to route shipments in the method which will result in the lowest cost unless otherwise instructed. All shipments will be freight charges collect except when stipulated on the purchase order, in which case you will be invoiced for all transportation charges. Delivery of material to a common carrier shall be considered to be delivery to Buyer and shall be at Buyer's risk thereafter. Claims of loss of or damage to material in transit shall be filed by the Buyer directly with the carrier.

**PRICES:** There will be added to all prices quoted sales, use, occupation or any other excise or similar tax which Seller may be required to pay or collect on or in connection with the sale. Seller shall be established by Federal, State or other government regulation with respect to the product(s) covered by the order which shall be lower than the price(s) specified in the order.

**ESCALATION TERMS:** Prices shown in this price schedule reflect the costs in effect at the time of publication. These prices will remain firm on all products with a quoted delivery of twenty-six (26) weeks or less. On products which have a scheduled delivery of more than twenty-six (26) weeks, the goods will be invoiced based on the applicable price sheet in effect at the time of shipment. In no event will the invoiced price be less than the price originally quoted.

**PURCHASED COMPONENTS:** (i.e. motors, gearing, etc.) Prices are quoted on supplier price in effect at time of quotation. Actual invoice Price will be adjusted in accordance with the supplier's escalation policy.

**DEFERRED SHIPMENTS:** If for any reason the customer desires to delay shipments more than 30 days after manufacturing is complete or to place a hold or stop to the order during the manufacturing cycle, The WALWORTH Company reserves the right to consider the order cancelled and to invoke cancellation charges per the schedule below.

**CANCELLATION:** After order acceptance by WALWORTH, items or completed orders may be cancelled and buyer will be charged for work performed, based on the following schedule:

- Five (5%) percent of prices of stock items.
- Ten (10%) percent of price of stock items ordered in quantities which exceed normal inventory levels.
- Five (5%) percent of prices prior to drawing submittal on made-to-order items.
- 15% after drawing approval, but prior to the start of castings.
- 30% to 50% during casting cycle, depending on the state of completion.
- 55% to 75% during machining and assembly operations, depending on the state of completion.
- 100% after final assembly and test.

**REMITTANCES:** Remittances must be made to the address indicated on the invoice.

**CREDIT TERMS:** As quoted. Invoices on balances overdue will be subject to a service charge of 11/2 % per month on such indebtedness.

**DELIVERIES:** Shipments and deliveries shall at all times be subject to the approval of Seller's Credit Department. If the Buyer shall fail to make any payments according to the terms of the contract, Seller may, in addition to and not in limitation of its other rights and remedies, at its option, cancel all or any part of Buyer's incomplete contracts with Seller or may defer shipments of deliveries under Buyer's contracts with Seller except upon receipt of satisfactory security or for cash shipment.

All schedule of shipments are estimated as closely as possible and Seller will use its best efforts to ship within the time scheduled, but does not guarantee to do so. Schedules commence with the date Seller receives authorization to proceed with order, subject to the provisions of the next sentence. The

order will not be released for manufacture until complete specifications and approved drawings (if drawing approval is required) are received at the plant of manufacture and the estimated schedule of shipment will commence with the date of such receipt.

Seller shall not be liable for any direct, indirect or consequential damage or loss caused by any delay in delivery, regardless of the cause of delay. Without limiting the generality of the foregoing, Seller assumes no responsibility for delays in delivery resulting from fire, flood, accidents, riots, strikes, transportation delays, labor or material shortages, existing or future laws, acts of any governmental authority, or any other cause beyond Seller's control. Items offered from stock are subject to prior sale.

**INSPECTION:** Final inspection and acceptance of products must be made at the plant of manufacture, unless otherwise provided in the order and/ or in agreed upon specifications. Prices do not include charges for special tests or inspections performed at the request of the Buyer, unless called for in the order and/or in agreed upon specifications.

**RETURNS:** Permission in writing and return tagging instructions must be obtained from Seller before any goods returned for credit or adjustment will be acceptance. Where returned goods are accepted, a minimum charge of 25% of the invoice price will be made, plus freight from both directions and costs of reconditioning the material for resale as new.

**WARRANTY CERTIFICATE:** WALWORTH, exhibits this product Warranty, for a 12 month period in operation or 18 months in storage, whatever comes first as of the date of product delivery.

WALWORTH, guarantees that products are fabricated according to quality, design and manufacturing standards and customer requirements as well. When the buyer expressly and in written confirms the non-compliance of such standards, WALWORTH is forced to comply with the repair, replacement or to issue the written authorization for the buyer or another agent, to replace or repair at no cost for the buyer, at WALWORTH fabrication costs, those parts confirmed as defective.

This warranty is valid when the material selection by the customer for the design, material arrangement (TRIM, bodies, ends, operation devices, etc.) internal and/ or external overlays had been the proper ones for the operation fluid. This warranty is applicable if operation and service conditions are maintained as per the requirements of the product.

To validate the Warranty, the user is responsible of performing the proper maintenance according to what is stated in the Operation and Maintenance Manual applicable to the product. WALWORTH, reserves the right to request the records (evidence) to confirm the correct maintenance.

WALWORTH obligations are limited and will be released of any responsibility when the products are altered, repaired or replaced without WALWORTH' s written authorization.

Except of what is stated in this document WALWORTH waives and excludes any other warranty expressed or implied, for loss, direct damage, indirect damage or consequential of other products, processes, installations or equipment of the buyer or end user, either partial or total, due to material defects and/or work and/or WALWORTH product design.

**DESIGN, ETC:** Seller reserves the right to change design, materials or specifications without notice. There will be a charge for modifying an order after it has been entered when such change or modification results in additional engineering or clerical work for either The WALWORTH Company or our suppliers.

**MINIMUM CHARGE:** Orders totaling less than \$100.00 USD net will be billed at a minimum charge of \$100.00 USD. Repair parts will be billed at a minimum charge of \$50.00 USD.

**NOTE:** We reserve the right to correct obvious clerical errors in quotations, invoices, and other contracts.





# WALWORTH®

Since 1842



[www.walworth.com](http://www.walworth.com)

MÉXICO

Industrial de Válvulas, S.A. de C.V.

Industria Lote 16 Sin Número, Fracc. Industrial El Trébol De Tepetzotlán, Tepetzotlán Estado de México C.P. 54610  
Phone: (52 55) 5899 1700 Fax: (52 55) 5876 0156 | e-mail: [info@walworth.com.mx](mailto:info@walworth.com.mx)

USA/CAN AUTHORIZED DISTRIBUTOR

TWC The Valve Company  
13641 Dublin Court, Stafford, Texas 77477 | Phone: (281) 566 1200 Fax: (281) 566 1299 |  
[www.twcvalves.com](http://www.twcvalves.com) | e-mail: [info@twcousa.com](mailto:info@twcousa.com)



Scan me with your smartphone to get more info about **WALWORTH** valves

